

# TECHBOOK

**The Swiss driving  
experience.**



EN | US

**+STROMER-**



# INDEX

<b>Marketing   Brand</b>	04
<b>Sales</b>	
· Corporate Service	06
· POS Material USD	08
· Configurator	11
<b>Service</b>	
· Contact	17
· Starter Kit	18
· Warranty provisions	19
· Warranty Processing	21
· Stromer Portal	26
· myStromer App	28
· Checklist	29
<b>ST1</b>	
· ST1 Tech	32
· ST1 Models	36
· ST1   V1 Spare Parts USD	38
· Service	50
· Type Approval	60
<b>ST2</b>	
· ST2 Tech	63
· ST2 Models	67
· ST2 Firmware Release	68
· ST2 Spare Parts USD	72
· Diagnosis	84
· Work Instructions	90
· Type Approval	99
<b>FAQs</b>	100

# STROMER BRAND

Stromer represents a new era in urban mobility. Our e-bikes provide the ideal solution for the challenges of modern commuting. Since opening our doors in 2009, true Swiss craftsmanship has been the guiding principle of everything we do.

By constantly striving for the highest quality, and pairing it with innovative technologies and a continuous effort to improve our design-standards, a new driving experience was born:

**The Swiss driving experience.**

## MISSION

To design and create premium e-bikes that enable riders to access new experiences and inspire them to think differently about modern commuting.

## POINTS OF DIFFERENCE

Superior build-quality, dynamic performance; Pure, fully integrated design; Commuter e-bike specialist; High-end brand.

## BRAND VALUES

Stromer stands for „Swissness“ – a unique attitude to life and a promise of quality, innovation, precision, reliability and respect for the environment.

## BRAND CHARACTER

Agile, Connected, Visionary, Hungry/Passionate

## TARGET

Urban, higher income individuals who aspire to live a modern balanced lifestyle, and continuously search for innovative ways of doing so.

## VISION

To facilitate a mental gearshift and turn commuting into a positive, rewarding experience.



## Stromer USA

Stromer USA | 9240 Trade Place Suite 100 | San Diego, CA 92126 | [service@stromerbike.com](mailto:service@stromerbike.com)  
[stromerbike.com](http://stromerbike.com) | [facebook.com/mystromer](https://facebook.com/mystromer) | [instagram.com/stromerbike](https://instagram.com/stromerbike)



**SALES**

## CORPORATE SERVICE

Do you want to keep your employees healthy and happy, do the environment a favor and raise your profile as an innovative and sustainable employer? Then why not consider a Stromer fleet? As a specialist in e-bike commuting, we can offer a solution tailored to your requirements.

Look forward to saying good morning to contented employees who have spent their commute doing a light morning work-out instead of sitting in traffic congestion, and have moreover enjoyed the drive. Who keep themselves fit and healthy as a result, boosting their productivity and commitment. Reduce your company's CO2 footprint with our award-winning e-bikes, and occupy less parking space. Switch to Stromer for local appointments or small errands, and project your company as both progressive and environmentally aware.

We will gladly visit your company with a Stromer fleet so that you can assess the advantages of our e-bikes for yourself. Equally, we can assist with branding your e-bikes and arrange for you to configure and order your ideal Stromer via our Retailers or using a special configurator tool.

### Emmi

In 2014 Switzerland's biggest milk processor Emmi teamed up with Stromer to launch a large-scale campaign to help Emmi employees buy Stromer ST1 e-bikes on special terms. "Our employees were thrilled. We had loads of requests to repeat the campaign," reports Emmi Senior Manager Max Peter, who also believes Stromer bikes have a key role to play within the company's own vehicle fleet: "On weekdays they are used by couriers. At weekends, they are available to employees for leisure use. Though you have to book them well ahead, that's how popular the Stromers are."



# CORPORATE SERVICE

## STROMER – THE SWISS E-BIKE

The Stromer e-bike is the optimum mobility solution for local travel for your employees. Many companies, from the small or medium-sized business to the international group, already use the Stromer for business travel. We at Stromer are able to offer an array of specific solutions. With the Stromer in your company, you are moving in the right direction!

### STROMER IN YOUR COMPANY – HOW YOU WILL BENEFIT

1 Image gain:

- You will position yourself as an innovative business
- You will reduce your CO2 emissions
- You will ease pressure on parking spaces

2 Increase of the motivation, health and productivity of your employees

3 Use of the Stromer as a PR and marketing instrument

4 Tax breaks (country-specific): depending on country, companies will enjoy tax breaks for using e-bikes.

### STROMER – FOR EMPLOYEE CAMPAIGNS

Stage an internal employee campaign offering the Stromer to your employees. We will provide all the instruments you need, free of charge. There is only a minimal amount of administrative work needed on your part. Consultations, test rides and deliveries are handled by our partner shops, to keep matters simple.

### STROMER – AS A FLEET

Use the Stromer as a mobility solution within your company. The Stromer is the ideal supplement to your vehicle fleet. You can brand your Stromer fleet with your company logo, or have them painted in your corporate colors. The Stromer is thus an appealing and environmentally friendly advertising instrument rolled into one!

### STROMER – AS AN ADVERTISING MEDIUM

Use the Stromer for the advertisement of your products and services. Whether in an advertising campaign, at a trade fair or during the launch of a new product: with the Stromer, you are the main topic of conversation and you attract attention – reaching your goal, thanks to Stromer.

### STROMER – WHAT WE OFFER YOU

- Apply logo to Stromer and/or supply entirely in your corporate colors
- Online configurator for ease of ordering wherever you are (via promotional code)
- Promotional materials in electronic form to publicize the campaign internally
- Roadshows at your premises for test rides
- Consultancy, test rides and delivery via all partner shops

### THIS IS HOW YOU CAN HELP YOUR EMPLOYEES TO PURCHASE A STROMER:

1 You provide a small subsidy towards the financing of a Stromer as a business vehicle as a way of promoting a healthy workforce.

2 You purchase a fleet of Stromers for your company. The e-bikes can be used by your staff and also for promotional purposes.

### CHOOSE A HIGH-QUALITY PRODUCT WITH THE FUN FACTOR – TRAVEL BY STROMER!

#### CONTACT:

Corporate Solutions

**Markus “Kusi” Eggimann**

Phone: 415-535-2741

[markus.eggimann@stromerbike.com](mailto:markus.eggimann@stromerbike.com)



# POS MATERIAL

Product	Price USD	Units	Order	Total USD
---------	-----------	-------	-------	-----------

Stromer Branded Shop Floor mats	\$25	1		
---------------------------------	------	---	--	--



Stromer Company Banner 200 x 70 cm Hanging Banner for a Wall	\$28	1		
---	------	---	--	--

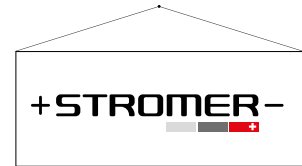

**Company Banner**  
200 x 70 cm

Stromer Catalogs	\$25	bx/120		
------------------	------	--------	--	--



Stromer Promo Pen Black	\$5	25		
-------------------------	-----	----	--	--



Stromer Sticker Black 10 x 4 cm	\$25	250		
Stromer Sticker White 10 x 4 cm	\$25	250		

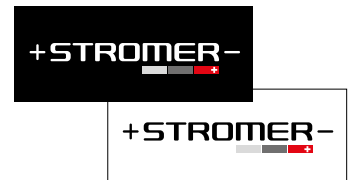

Page Total (USD)				
------------------	--	--	--	--



# POS MATERIAL

Product	Price USD	Units	Order	Total USD
Stromer Shop Floor Display	\$100	set		



10'x10' Tent and frame (5 wks delivery)	\$400	1		
Tent and frame carrier bag	\$100	1		



Stromer Beach Flag Outdoor 510 cm Complete Set	\$75	1		
Stromer Beach Flag Outdoor 510 cm <b>Only Flag</b> /replacement flag	\$25	1		

**Beach Flag**  
Complete Set  
Outdoor 510 cm



**Deco Flag**  
Complete Set  
Indoor 180 cm



Stromer Deco Flag Indoor 180 cm Complete Set	\$25	1		
Stromer Deco Flag Indoor 180 cm <b>Only Flag</b> /replacement flag	\$15	1		

Grand Total (USD)				
-------------------	--	--	--	--



# CONFIGURATOR

## INSTRUCTIONS

All Stromer e-bike orders are submitted through the configurator. Retailers and end customers can configure and order a Stromer through the configurator. As the Retailer is the contractual partner of myStromer AG for all orders, every order must be confirmed by the Retailer before it is processed by Stromer.

Please refer to the T&Cs / Terms of Use for the precise contractual relationship.

### 1 FUNCTIONS

The Stromer configurator can be reached on the following link: [www.stromerbike.com/build-your-bike](http://www.stromerbike.com/build-your-bike)

#### 1.1 GENERAL FUNCTIONS

- Ready to order – a fully configured e-bike when the configurator is started up – can be modified according to personal requirements.
- Availability of the desired configuration is shown.
- Configuration can be shared on the usual social media.
- Clear selection process for options
- Changes to the configuration are indicated visually.
- Retailer selection – the nearest Retailers are suggested based on the customer's address.
- Easy access to corporate deals & promotions

#### 1.2 FUNCTIONS FOR RetailerS WITH LOGIN

- Orders summary
- Confirming orders
- Editing orders
- Orders for shop stock

### 2 PROCESS

Every order involves the following steps. The status of an order is shown in the myStromer area. The order has only been completed when the status "Delivered".

**IMPORTANT:** It is very important that the Retailer confirms an order so that it can be processed by Stromer. Only when the order reaches Ordered status is the order recorded, built and shipped to the Retailer.

If the Retailer selects the "from own stock" option, the Stromer can be shipped direct to the customer from the Retailer's stock, which means no order is sent to Stromer.

#### CONFIGURED

Customer has configured an e-bike and stored his user details.

#### NEW

Customer has accepted the T&Cs and placed the order.

#### CONTACTED

Retailer contacts the customer for the purposes of accepting the order.

#### ORDERED

Retailer confirms the order to Stromer. Only then does Stromer process the order.

#### SHIPPED / FROM OWN STOCK

The Retailer has shipped the Stromer to the customer.

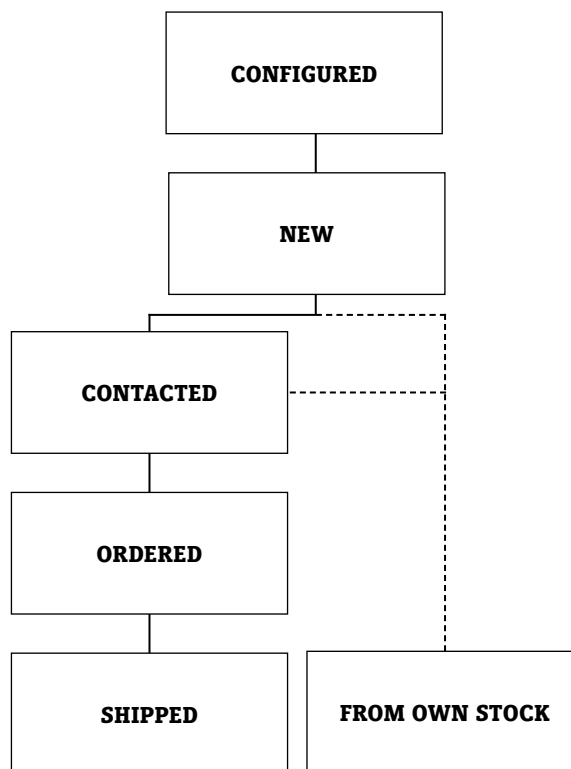

# CONFIGURATOR

## INSTRUCTIONS

### 3 CONFIGURATION

#### 3.1 BIKE

1. Access to corporate deals & campaigns
2. Choose model ST1 or ST2
3. Select options
4. Preview
5. Price display
6. Display of availability
7. Share & print configuration

#### 8. Order

9. Overview of order progress
10. Overview of configuration
11. Modify configuration
12. Select quantity
13. Add new configuration
14. Continue

#### 3.2 ACCESSORIES

15. Overview of order progress
16. Add accessories to cart
17. Display cart
18. Continue

**1** **2** **3** **4** **5** **6** **7**

**8** **9** **10** **11** **12** **13** **14**

**15** **16** **17** **18**

**YOUR SHOPPING CART (2)**

PRODUCT	DESCRIPTION	QUANTITY	PRICE	TOTAL PRICE
ST2 Spare Drive axle Spurt 17 EDMA	Edma	2	CHF 690.00	CHF 1380.00
ST1 Spare Drive axle Spurt 17 EDMA	Edma	1	CHF 30.00	CHF 30.00
			<b>TOTAL CHF 7'020.00</b>	

**YOUR SHOPPING CART (2)**

PRODUCT	DESCRIPTION	QUANTITY	PRICE	TOTAL PRICE
ST1 Spare Drive axle Spurt 17 EDMA	Edma	1	CHF 30.00	CHF 30.00
			<b>TOTAL CHF 7'020.00</b>	

**ACCESSORIES**

CHOOSE YOUR ACCESSORY

ACCESSORY	PRICE
ST1 SPARE BATTERY 913PM	CHF 960.00
ST1 SPARE BATTERY 91522	CHF 1200.00
ST1 TRAILER PLATE	CHF 45.00
ST1 BOB TANK TRAILER NUTS	CHF 55.00

# CONFIGURATOR INSTRUCTIONS

## 4 ORDER CONFIGURATION

### 4.1 CUSTOMER DATA

- 19. Overview of order progress
- 20. Customer data – fields marked \* are mandatory
- 21. Select to sign up for newsletter
- 22. Continue

NOTE: When the Retailer has logged in, they can choose whether the order is intended for a customer or for their own stock. The customer data is not required for stock orders.

### 4.2 COLLECTION LOCATION

- 23. Overview of order progress
- 24. Search location
- 25. Map with Retailer display
- 26. Select Retailer as collection location
- 27. Continue

#### Status: “Configured”

As soon as the customer data and collection location have been recorded, the order progresses to the status Configured.

NOTE: When the Retailer has logged in, no collection location is requested. The Retailer logged in is automatically selected.

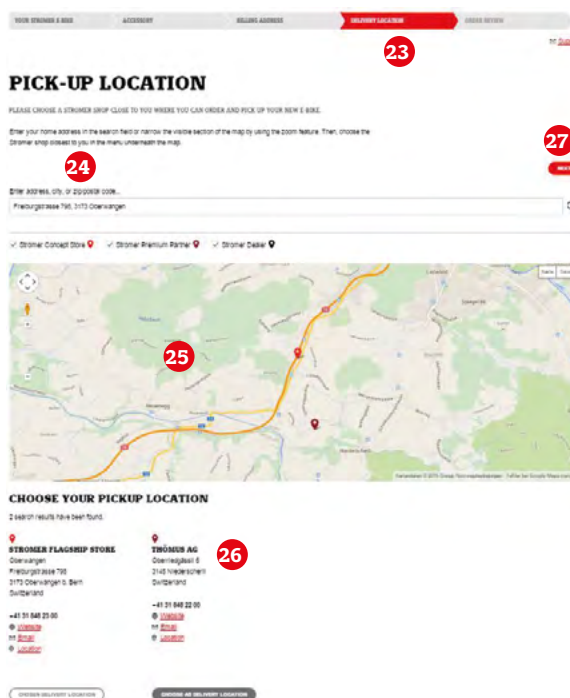
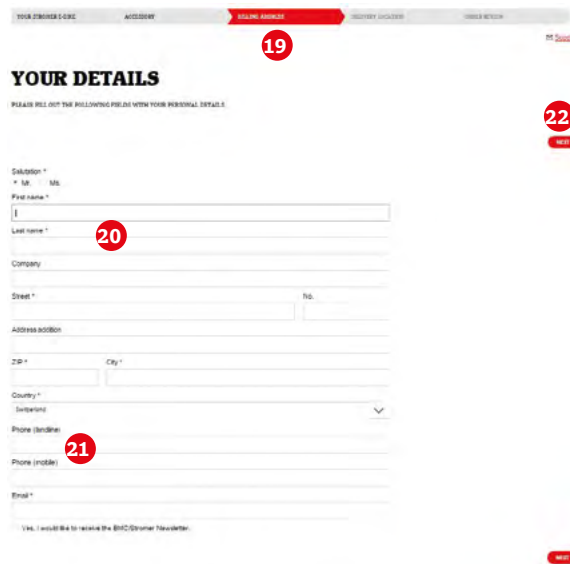

# CONFIGURATOR

## INSTRUCTIONS

### 4.3 ORDERING

28. Overview of order progress
29. Orders summary
30. Click pencil to edit data
31. Confirm T&Cs
32. Place order

#### Status: "New"

As soon as the T&Cs are accepted and the order is placed, the order progresses to the status New.

The customer and the selected Retailer are notified by email.

**ORDER OVERVIEW**

CONFIRM YOUR ORDER AND PROCEED TO CHECK OUT.

Thank you for ordering a Stromer e-bike. We wish you lots of fun and joy with your new purchase. Always ride safely.

**YOUR ORDER** TOTAL CHF 7 020.00

PRODUCT	DESCRIPTION	QUANTITY	PRICE	TOTAL
STC	Stryke Drive with Speed 17.8 km/h	1	CHF 6900.00	CHF 6900.00
Vehicle Documents				CHF 120.00
CUSTOMER DATA				
Salutation	Mr.	Christoph		
First Name	Christoph			
Last Name	M. Strome AG			
Company	Paradeplatz 118			
ZIP Code	3173 Bollingen			
Country	Switzerland			
Phone (optional)	CH 78 662 00 00			
E-Mail	christoph.strome@stromer.ch			
Headset	No			
PICK-UP LOCATION				
Company	Strome / MyStromer Store	Chambray		
Street	Paradeplatz 118			
ZIP Code	3173 Bollingen			
Phone (optional)	CH 78 662 00 00			
LEGEND				
<ul style="list-style-type: none"> <li>1. A Strome e-bike will automatically get in touch with you regarding your order. The document of us will be the delivery of your new e-bike.</li> <li>2. You must enter the payment of your e-bike at the Strome store.</li> </ul>				
			<b>TOTAL CHF 7 020.00</b>	
				<a href="#">I accept the general terms and conditions (GTCL)</a>
				<a href="#">confirm order</a>

### 5 MANAGE ORDERS

It is very important that an order is confirmed by the Retailer to allow it to be processed by Stromer. Only when the order reaches Ordered status is the order recorded, built and shipped to the Retailer.

We recommend that you check the status of orders on a regular basis.

#### 5.1 LOGIN - MYSTROMER

1. Select desired country and language
2. Click on LOGIN
3. Enter Username – same as your customer number
4. Enter password – if you do not yet have a password, request it from Customer Service.
5. Click on LOGIN button

6. Click on MYSTROMER to open the orders summary

User name  Password  [Forgot your password?](#) [LOGIN](#)

LOGIN | SWITZERLAND | DE | FR | IT | EN | Q

**+STROMER-**

MYSTROMER | LOGOUT | SWITZERLAND | DE | FR | IT | EN | Q

**+STROMER-**

# CONFIGURATOR INSTRUCTIONS

## 5.2 ORDERS SUMMARY

- 7. Status filter
- 8. Free text search
- 9. Click on the order number to edit and change the status  
New orders have the status "New"

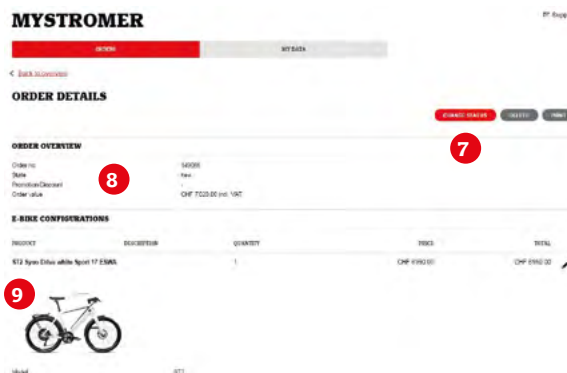

## 5.3 CONFIRM ORDERS

Important: Stromer only processes orders with the status "Ordered"

- 10. Change status
- Step 1: "New" --> "Contacted"
- Step 2: "Contacted" --> "Ordered"

Or directly: "New" --> "Ordered"

- 11. Delete order\*
- 12. Edit configuration\*

\*To edit or delete configurations, the status must be set to "Contacted".

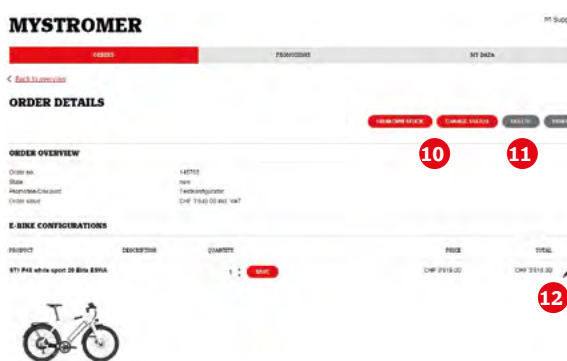

## 5.4 DELIVERY

When the customer has collected his/her bike, the Retailer concludes the process by changing the status to "Delivered".

- 13. Change status from Ordered to "Delivered".

This is the last possible status. The process is complete.

## 5.5 DELIVERY EX RETAILER'S STOCK

If the Retailer has the desired bike in stock, the bike can be shipped to the customer direct from the Retailer's stock.

- 14. From own stock
- 15. From own stock à status changes to "from own stock"

This is the last possible status. The process is complete. No order is sent to Stromer. The additional Corporate Level discount for Local and Factory Deals is refunded quarterly for shipments from the Retailer's stock.

This function is only available for Corporate Solutions and special promotions.

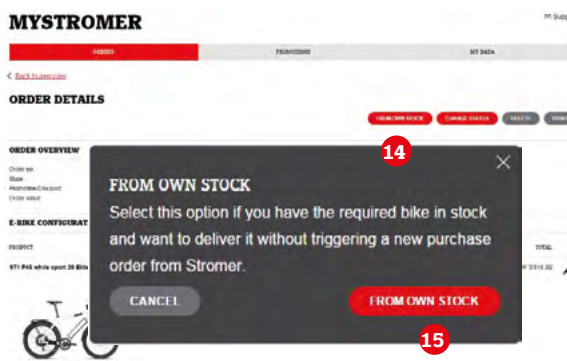



# CONTACT

## US GENERAL MANAGER



**MARKUS EGGIMANN**  
US GENERAL MANAGER  
markus.eggimann@stromerbike.com  
Phone: 508-868-8109

## SUPPORT USA

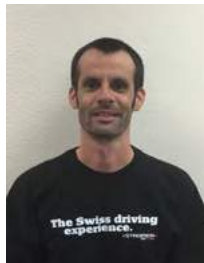

**JOEL MONTECALVO**  
SERVICE MANAGER  
service@stromerbike.com  
Phone: 1-800-819-4262 ext. 111

## SALES TEAM USA



**JUSTIN MANTHE**  
NATIONAL SALES DIRECTOR  
justin.manthe@stromerbike.com  
Phone: 760-390-3560



**CHAN HUYNH**  
RETAILER SERVICES COORDINATOR  
service@stromerbike.com  
Phone: 1-800-819-4262 ext. 112



**JAMES MERCIER**  
REGIONAL SALES MANAGER - EAST  
james.mercier@stromerbike.com  
Phone: 508-868-8109

## OPERATIONS USA



**NADJA EGGIMANN**  
INSIDE SALES  
nadja.eggimann@stromerbike.com  
Phone: 1-800-819-4262 ext. 108

## MARKETING USA



**SCOTT ANDERSON**  
US MARKETING MANAGER  
scott.anderson@stromerbike.com  
Phone: 612-232-7651



**OLIVER DINE**  
OPERATIONS MANAGER  
oliver.dine@stromerbike.com  
Phone: 1-800-819-4262 ext. 107

## FINANCE USA



**DONNA SEAL**  
US FINANCE MANAGER  
donna.seal@stromerbike.com  
Phone: 760-828-3890



# STARTER KIT RETAILER

The starter kit is available on a once-only basis from the local field force member.

## ST1 STARTER KIT

NAME
TMM Sensor ID Bike v2.0 ST1
Wicked Cable ST1
Charging Socket ST1
Battery Assembly ST522 BA
Magura Brake Kit Front ST1
Magura Brake Kit Rear ST1
Power Cable ST1
Display Assembly UI-ST1.01.01
Rear Wheel Assembly P48 RW-ST1.02.01
Comperssor ST1
Bottom Bracket FSA BB-AL7420AL
Wicket Lock Kit ST1
Motor Accessories Nut and Spacer Kit ST1
Short Plug Programming ST1
Freewheel SunRace 9-Speeds MFEX9 11-32t kit
Programming Cale ST1
Light Y-Cable Frame ST1
Fender Kit ST1
Light Y-Cable Frame ST1 M16
Rear Wheel Black Spokes MY16 ST1 *
Rear Wheel Assembly M33 RW-ST1.01.01 *

**Price Starter Kit: 1475.– USD**

\* Optionally available for 600 USD

## ST2 STARTER KIT

NAME
Light Rear B+M Toplight Mini incl. Cable & plug
Battery Assembly ST2 ST814
TMM Sensor Plate Dropout SP Kit ST2
Cable inlet ST2
Controller Kit ST2
User Interface SP Kit ST2
Button Ring Kit ST2
Nut Tool ST2
Front Axle SP Kit ST2
Motor Connector Syno Drive SP Kit ST2
Rear Axle SP Kit ST2
Seat Clamp SP Kit ST2
Light Holder Supernova Stemlight SP Kit ST2
Light Front Supernova Stemlight SP Kit ST2
Brake Front Magura SP Kit ST2
Brake Rear Magura SP Kit ST2
Rear Wheel SYNO Drive SP Kit ST2
Top Cap ST2
Charging Socket ST2
Brake Sensor Cable ST2
Freewheel Body Formula SP Kit ST2
Motor Controller Cable ST2
Can Portector ST2
Seat Clamp SP Kit ST2 new
Button Ring Kit ST2 S

**Price Starter Kit: 2075.– USD**



# STROMER WARRANTY PROVISIONS AND LIMITATION OF LIABILITY

myStromer AG (hereinafter: STROMER) congratulates you on the purchase of your new STROMER product. Our name stands for the highest quality, durability and functionality during the definition, production and machining of the materials used as well as for a captivating appearance in the processing, concept and design.

To ensure that you can use your high-quality product from STROMER to experience unlimited enjoyment and riding fun over many years, certain rules must be adhered to that are defined below and specifically in your operating instructions.

Bringing the bikes into their definitive ready-for-road state and therefore assuring riding safety, in particular adjusting the seat position, suspension, gears and brakes to suit the end user, must be performed exclusively by trained specialists.

You as the end customer shall be designated and addressed as buyer (hereinafter: buyer).

These warranty provisions shall regulate the warranty services of STROMER to the buyer and the preconditions under which claims can be made on the warranty services. The complete warranty provisions as well as the operating instructions can be consulted at any time on the STROMER website: [www.stromerbike.com](http://www.stromerbike.com)

## 1. MANUFACTURER WARRANTY

Upon presentation of the original receipt of purchase, the buyer shall be entitled to the warranty services as set forth in the following provisions.

## 2. PRODUCTS COVERED BY THE WARRANTY

The warranty shall cover all STROMER-specific components that are available exclusively from STROMER Retailers, hereinafter referred to as STROMER products. The warranty extends exclusively to STROMER products that are new and exhibit a material or production defect. All other parts and components shall be excluded from this warranty.

Original bike components supplied by 'other manufacturers (in other words, non-STROMER products) shall be subject to the warranty provisions of the manufacturer in question.

## 3. WARRANTY PERIOD

ST1: 2 years  
ST2: 2 years  
ST2 S: 3 years

Irrespective of model:

- Frame – 3 years
- Paint – 3 years
- Battery - 75% of capacity within 2 years

## 4. SCOPE OF THE WARRANTY SERVICES

STROMER assures the following services on the basis of this warranty throughout the respective warranty periods:

- At STROMER's discretion, repair or replacement with parts/components of the same value, whereby the replacement may vary from that being replaced with regard to the model and/or color;
- Services that are not covered by the warranty and that are within the area of competence of the STROMER Retailer, such as the cleaning of STROMER bikes delivered in a dirty state, are charged according to the usual hourly rates. Material and transport are charged at cost;
- STROMER again grants a 2-year warranty on a repair performed or replacement part fitted during the warranty period due to a material or production defect, irrespective of other warranty periods;
- If a STROMER bike is exchanged in full for a new one due to a material or production defect, the same warranty provisions as for a newly purchased STROMER bike shall apply.

## 5. WARRANTY EXCLUSION

The following components/parts and circumstances shall be excluded from this warranty or lead to exclusion from this warranty:

- If the vehicle is technically modified without the approval of the manufacturer
- Subsequent conversion/installation of incompatible or non-original parts (see operating instructions)
- Wearing parts (see definition of wearing parts given below)
- Non-STROMER parts/components
- Any modification of the version as delivered
- Repairs that have not been carried out by trained specialists
- Inappropriate use/transport (see operating instructions)
- Missing service inspections within an appropriate period (see operating instructions)
- Inappropriate maintenance/operation/upkeep (see operating instructions)
- Damage resulting from omitted or incorrect adjustment(s) or worn components
- Consequences of a fall
- Damage caused by climatic conditions or normal wear
- Damage due to unsuitable cleaning agents, utensils such as high-pressure cleaners or the additives used
- Commercial lending/transfer

# STROMER WARRANTY PROVISIONS AND LIMITATION OF LIABILITY

The following parts shall constitute wearing parts and be excluded from this warranty:

- Bump stops in forks and shock systems
- Coatings on fork stanchions and shock absorber pistons
- Moving parts made from rubber
- Brake pads
- Brake disks
- Seals
- Springs
- Rim flanges/brake surfaces
- Freewheel bodies
- Slide rings and plain bushes
- Bar grips and handlebar tape
- Cassettes, cogs, chain rings
- Chains
- Bearings and bearing seatings
- Airtight seals/O-rings
- Tires
- Shifting lever rubber coatings
- Shifting components
- Foam parts
- Fenders, chain guide
- Actuating cables and outer sleeves
- Spokes
- Dust rings

## 6. ASSERTION AND PROCEDURE OF WARRANTY CLAIMS

Warranty claims are to be submitted to your STROMER Retailer in conjunction with presentation of the original receipt of purchase from a STROMER Retailer. The warranty period shall run from the date of sale/registration or activation (whichever is the sooner).

Your STROMER Retailer shall report your warranty claim, including a description and the serial numbers of the defective parts and the frame number, to STROMER, which shall decide on the further procedure immediately upon receipt of the warranty claim. Should clarification require the parts to be checked, these shall be removed and submitted to STROMER in a clean state.

Products repaired or replaced under the warranty shall be sent to the STROMER Retailer. Assembly and basic adjustment must be performed by the STROMER Retailer. Should these preconditions not be adhered to, warranty claims of any kind can be rejected.

## 7. SEVERABILITY CLAUSE

Should a provision from this warranty be or become invalid or exhibit a loophole to be closed, the legal force of the remaining provisions shall remain unaffected. Instead of the missing or invalid provision, a provision that comes as close as possible to the meaning of the original provision shall be agreed.

## 8. APPLICABLE LAW AND PLACE OF JURISDICTION

For all disputes from or in conjunction with this warranty (also with regard to the question of its conclusion or validity), the exclusive jurisdiction of the courts from the City of Bern shall be agreed. This purchase contract shall be subject to Swiss law with the exclusion of a conflict of laws as well as the United Nations Convention on Contracts for the International Sale of Goods (CISG).

myStromer AG  
Freiburgstrasse 798  
3173 Oberwangen  
Switzerland  
Phone +41 (0)31 848 23 00  
info@stromerbike.com

## NO FURTHER WARRANTY CLAIMS:

THE WARRANTY PROVISIONS OF STROMER ARE COMPREHENSIVE AND DEFINITIVE.

IN PARTICULAR NO PARTY (INCLUDING THE STROMER Retailer) IS OR SHALL BE AUTHORIZED BY STROMER TO GRANT ANY GUARANTEES OR OTHER WARRANTY ENTITLEMENTS OR RIGHTS OVER AND ABOVE THESE WARRANTY PROVISIONS.

EXCLUSIVELY STROMER SHALL BE AUTHORIZED TO RULE ON ANY WARRANTY CLAIMS FOR STROMER PRODUCTS.

LIMITATION OF LIABILITY AND EXCLUSION OF LIABILITY:

STROMER'S LIABILITY FOR DAMAGE RESULTING FROM DEFECTS TO THE STROMER PRODUCT SHALL ALWAYS BE LIMITED AT MOST TO THE ORIGINAL PURCHASE PRICE OF THE STROMER PRODUCT IN QUESTION.

STROMER SHALL THEREFORE IN NO CIRCUMSTANCES ACCEPT LIABILITY FOR DAMAGE CAUSED BY FORCE MAJEURE EVENTS, CHANCE OCCURRENCES AND/OR UNFORESEEABLE EVENTS, OR CONSEQUENTIAL DAMAGE, IN OTHER WORDS FOR DIRECT OR INDIRECT DAMAGE, LOST PROFIT OR OTHER LOSSES THAT MAY RESULT FROM A DEFECT TO A STROMER PRODUCT.

ANY LIABILITY FOR DAMAGE THAT MAY OCCUR THROUGH USE OF THE STROMER PRODUCT BY THIRD PARTIES SHALL LIKEWISE BE EXCLUDED. SOLELY THE BUYER OR RIDER SHALL BE RESPONSIBLE FOR SUCH DAMAGE TO THIRD PARTIES.

THE ABOVE LIMITATION OF LIABILITY AND THE EXCLUSION OF LIABILITY SHALL NOT APPLY TO THE EXTENT THAT STROMER IS LIABLE ON THE BASIS OF LEGALLY COMPULSORY REGULATIONS.

# WARRANTY PROCESSING

More precise case tracking offers greater understandability for everyone involved - responsibilities and costs are transparent. Google Drive will be deactivated with the introduction of the new process. The warranty claims already registered in Google Drive will be transferred to the Stromer portal.

## 1. CREATION OF A NEW WARRANTY CLAIM

### 1.1 OPEN THE WARRANTY INPUT MASK IN THE STROMER PORTAL

1. Open the Stromer portal ([www.stromer-portal.ch](http://www.stromer-portal.ch))
2. Click on the „Create new claim“ button under „Warranty“

### 1.2 FOLLOW THE INSTRUCTIONS OF THE INPUT MASK

We can identify the Stromer and check the warranty term based on the VIN or serial number of the repaired Stromer. We ensure the correct processing of the warranty case by specifying the replaced articles and describing the fault.

If we have no warranty date stored, we ask that you attach the warranty card or the sales receipt. You will then be prompted to specify a warranty start date for the Stromer. If the Stromer is no longer within the warranty period, you will automatically be forwarded to the goodwill claim. For the goodwill claim, you must additionally select a reason.

### 1.3 FURTHER PROCEDURE FOLLOWING THE WARRANTY CLAIM

As soon as the claim is completed, you will be shown a summary with the case number. You will also be shown what you must do with the defective article.

**If the defective article is to be returned, we ask that you print out the warranty document and send this together with the defective article to the listed address.**

Important: The warranty document can only be assigned to one particular article. Please clearly attach the document to the associated article.

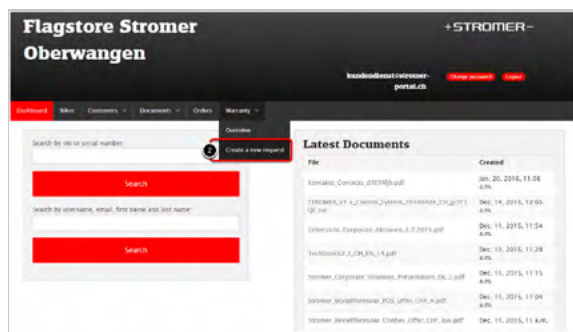

## 2. OVERVIEW OF THE WARRANTY CLAIMS

1. Open the Stromer portal ([www.stromer-portal.ch](http://www.stromer-portal.ch))
2. Click on the „Overview“ button under „Warranty“

# WARRANTY PROCESSING

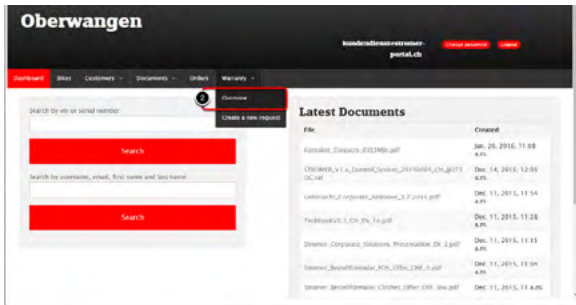

## 2.1 WHAT INFORMATION IS SHOWN IN THE OVERVIEW?

1. Case number: Reference number for the case on hand
2. VIN: Identification number of the affected Stromer
3. Workflow: Shows the state of work of the case
4. Handling code: Reference for the fault from the case
5. Instructions: Case-specific instructions about what to do with the defective part
6. Compensation: The amount which you are to be compensated for this case
7. Last modified: Last change to the case
8. Customer ID: Your customer number

## 2.2 DEFINITION AND MEANING OF THE „WORKFLOW“ COLUMN

Workflow	Meaning	Activity of myStromer AG	Activity of dealer
Created	The claim was created		
In progress	The claim is being processed at Stromer	Processing of the claim	
Pending shipment	The shipment of the article is outstanding		If the defective article is to be returned, we ask that you print out the warranty document and send this together with the defective article to the listed address
Part shipped	The spare part was dispatched	Processing of the delivery	
Defective part not yet arrived	The defective article has not yet arrived at the stipulated address		Please ensure that the defective article is sent
Pending repair	The repair of the defective part is still outstanding		
Repair in progress	The repair of the defective part is in progress	Processing of the repair	
Pending compensation	The compensation is outstanding	Processing of the compensation	
Performed compensation	The compensation was carried out: The claim is completed		
Rejected	The claim was rejected	Making contact with the dealer	Making contact with Stromer

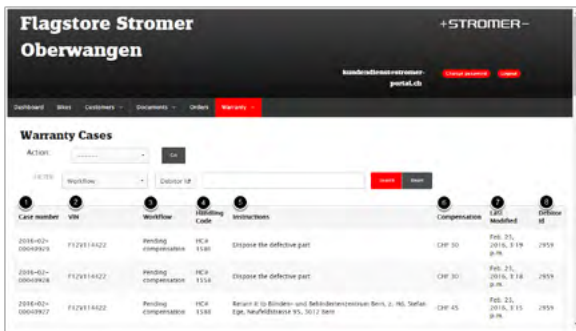

# WARRANTY PROCESSING

## RETURNS PARTS

### **PURPOSE**

The guidance provided below governs the return of parts in warranty claims.

### **BACKGROUND**

To enable myStromer AG to process defective parts, these must be notified in advance using the warranty claim procedure.

- 1 Create a warranty claim. Instructions: «Filing a warranty claim»
- 2 Print the PDF next to the respective claim on the portal and attach it to the component that is to be returned.

## RETURNS PARTS ST1

Art.#	description	return	dispose	ST-Typ
213431	Battery Assembly ST396 11Ah	x		ST1
213434	Battery Assembly ST522 14.5Ah	x		ST1
213493	rear brake Magura	x		ST1
213609	Display Assembly	x		ST1
215871	Fork rigid red 300mm	x		ST1
215872	Fork rigid white 300mm	x		ST1
215873	Fork rigid black 300mm	x		ST1
213615	Fork Assembly Carbon red 300mm	x		ST1
213616	Fork Assembly Carbon white 300mm	x		ST1
213617	Fork Assembly Carbon black 300mm	x		ST1
213452	Fork Assembly SR red 300mm	x		ST1
213453	Fork Assembly SR white 300mm	x		ST1
213454	Fork Assembly SR black 300mm	x		ST1
219578	Battery Charger ST1	x		ST1
219486	Light Front Supernova E3 30-43V	x		ST1
213515	Light Front B+M Lumotec IQ Fly E 42/6V	x		ST1
213517	Light Rear B+M Toplight Mini	x		ST1
213623	Rear Wheel Assembly P48	x		ST1
216198	Rear Wheel Assembly P48 refurbish	x		ST1
213622	Rear Wheel Assembly M33	x		ST1
216206	Rear Wheel Assembly M33 refurbish	x		ST1
216933	Freewheel SunRace 9-Speeds 11-32t kit		x	ST1
215867	Brake Sensor ST1 Kit		x	ST1
213430	Display Housing clamp		x	ST1
213414	TMM Sensor ID Bike		x	ST1
218472	TMM Sensor Plate Dropout ST1 Kit		x	ST1
213415	TMM Sensor Cable incl. Connector		x	ST1
213426	Charging Socket		x	ST1
213608	Power Cable (3-Pin)		x	ST1
213425	Wicket Cable		x	ST1
213427	Display Cable extension		x	ST1
219167	Light Y-Cable Frame		x	ST1



## RETURNS PARTS ST2

Art.#	description	return	dispose	ST-Typ
219554	Battery 814WH	x		ST2
221332	Brake front	x		ST2
221334	Brake rear	x		ST2
221242	Fork ST2	x		ST2
221071	Controller	x		ST2
221244	Motor connector	x		ST2
221342	Charger version US	x		ST2
221253	Supernova head light	x		ST2
213517	Light rear B+M Toplight Mini	x		ST2
221074	User interface	x		ST2
221336	Rear wheel assembly syno drive	x		ST2
221070	Distribution board		x	ST2
221370	Motor Controller cable		x	ST2
221349	Brake sensor cable		x	ST2
221348	Charging socket		x	ST2
221072	Daytime light		x	ST2
221050	TMM Sensor Plate		x	ST2

# STROMER PORTAL

## QUICK-START GUIDE

### STROMER ST1/ST2 ACTIVATION IN THE PORTAL FOR WARRANTY AND OMNI

#### ACTIVATING A STROMER IN THE STROMER PORTAL

To get to the Stromer portal, please enter the following web address into your browser:

**https://stromer-portal.ch/shops/login**



You can then log in with your individual "Username" and "Password" (the password was sent by email. If you have forgotten it, please send an email to support@stromer-bike.com).



When you have successfully logged in, the "Dashboard" menu will appear automatically.

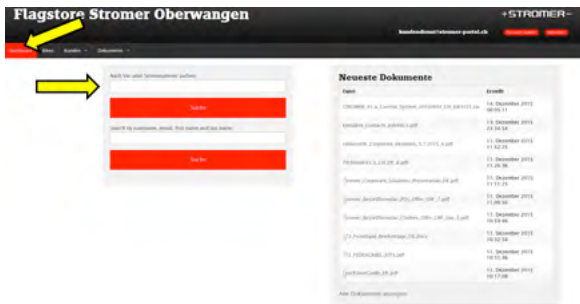

Determine the desired Stromer using the corresponding VIN.

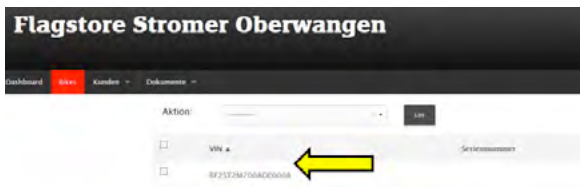

Please check the VIN again and select it accordingly.

The Stromer can now be assigned to its new owner.

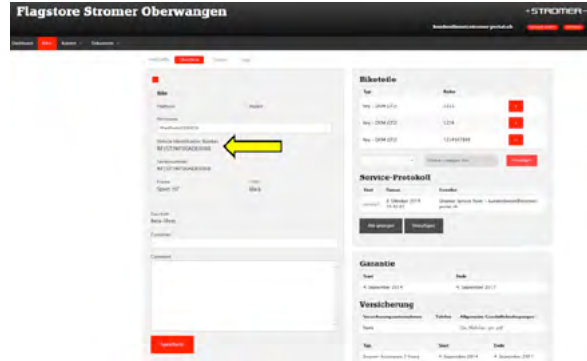

The portal offers the following options for linking the customer to a Stromer:

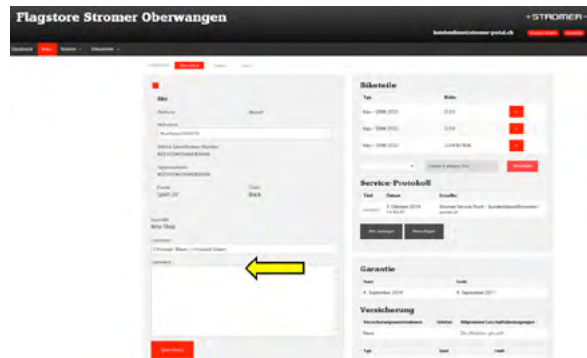

1. Enter the name of the customer in the search field (the name appears if the customer is already registered in the shop).
2. Add the customer if the customer is not yet registered.

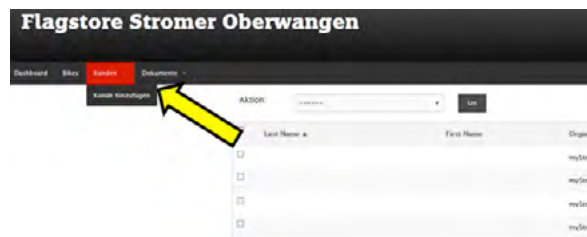

Enter all required customer data (please check that the cell phone number and the email address are entered in the correct format). Then please click on "Save".

After creating a new customer, the corresponding VIN must once again be determined and selected, as described on page 3.

Enter the newly created customer in the "Customer" search field and also select this.



# STROMER PORTAL

## QUICK-START GUIDE

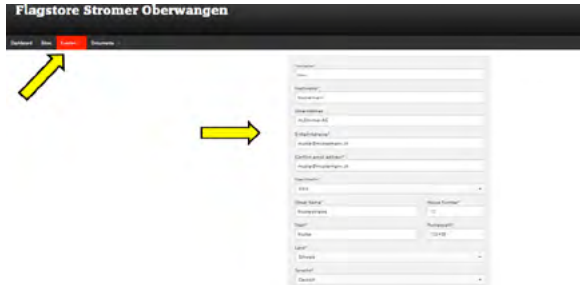

Then click on "Save". Owner and Stromer are now linked.

To finish the activation process, click on "Activate":

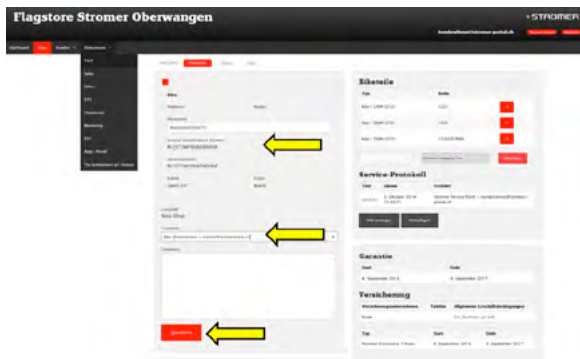

Once you have successfully activated the Stromer, you can select the desired Assistance (1-3 year/s) and continue (CH market only).

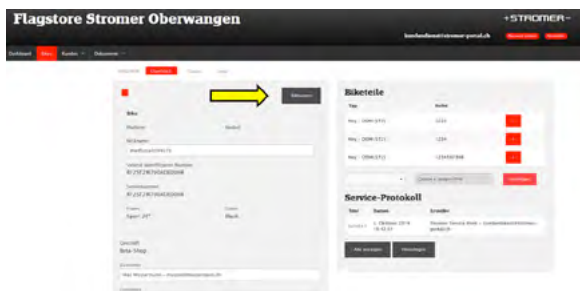

The term for the warranty and the Assistance (CH market only) is shown. Then be sure to mark and confirm the data protection guidelines (inform the customer).

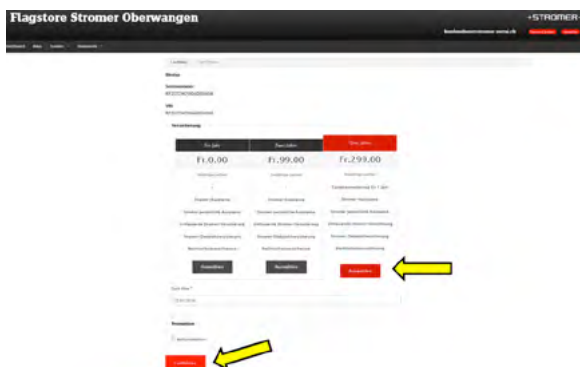

Red bar: Stromer is not online (OFF), PIN is confirmed as soon as the Stromer is online (ON) and has connectivity (customer receives email/SMS with PIN)  
Green bar: Confirmation that the activation is completed

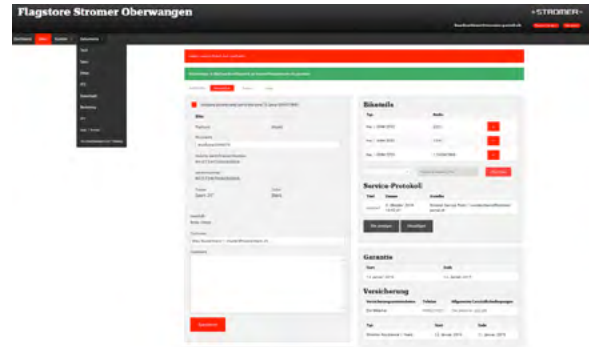

Registration of the Stromer and its new owner and the desired Assistance (CH only) on the part of the Retailer is now finished.

The new Stromer owner receives an email with the current T&Cs following registration. **The customer must confirm these in order to complete the activation of the Stromer.**

### STROMER APP

Full information about the Stromer App can be found at [www.stromerbike.com](http://www.stromerbike.com) (Support/Support ST2/Stromer App).

### OMNI

Full information about OMNI can be found at [www.stromerbike.com](http://www.stromerbike.com) (Support/OMNI).

If you have any further questions about registration/activation or Assistance/App/OMNI, please do not hesitate to contact our customer service team ([support@stromerbike.com](mailto:support@stromerbike.com))



# MYSTROMER APP

## MYSTROMER APP

The myStromer app is available for iOS and Android smartphones. In conjunction with a Stromer with OMNI, the app opens new functions such as tuning, tracking, anti-theft mode, etc.

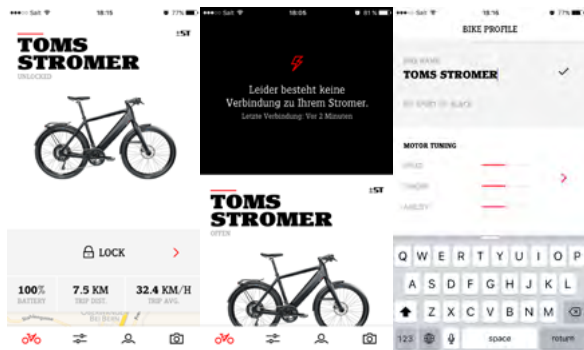

### 2.1 USERNAME

The end customer is given the access data for the app by their Retailer. This happens as soon as the Retailer records a new customer in the portal and allocates them a Stromer e-bike. The email address stored in the portal serves as the username that is used to log into the myStromer app.

REMARK: To demonstrate the full functionality of the display bikes, a Retailer needs a demo account. Every Retailer can set up a demo account themselves by creating a demo customer. When doing so, please note the following:

1. A valid email address must be used. The email address is required to set a password.
2. It is not possible to use the same email address as for shop access to stromerportal.ch.

Some ST2 Retailers were given a demo account at launch. The account name is xyz@st2launch.ch, where 'xyz' varies from Retailer to Retailer. The emails are forwarded to the Retailer's main email address.

### 2.2 REQUEST PASSWORD

The first time the myStromer app is started, a password can be requested from the email address registered in the portal by the Retailer.

- Shortly afterwards you will receive an email with a link to change the password.
- The link takes you to a website where a new password can be set.
- This password can then be used to log into the myStromer app

## 3 IMPORTANT NOTES

Updating the status and position data and sending commands may take several minutes, depending on mobile reception, or may not succeed.

The data is not updated automatically. The data is only updated on request through the myStromer app. The maximum update frequency is every 10 minutes.

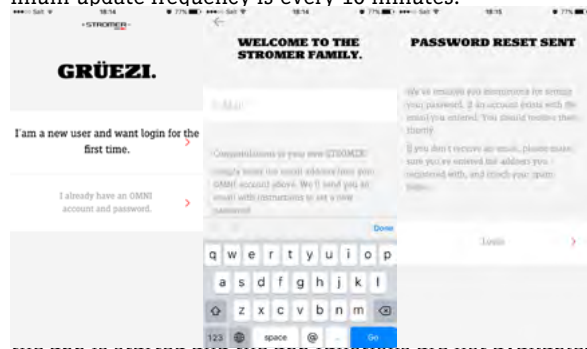

# CHECKLIST

## FINAL RETAILER INSPECTION

● **ST1**   ● **ST2**

	<b>ITEM</b>	<b>CHECKING PROCESS</b>	
<input type="radio"/>	<input type="radio"/>	1. Incoming goods	<ul style="list-style-type: none"> <li>• Check incoming e-bikes for signs of damage in transit and, where applicable, make a written note of any damage with the carrier</li> </ul>
<input type="radio"/>	<input type="radio"/>	2. Delivered goods	<ul style="list-style-type: none"> <li>• Check that the delivery concurs with the order confirmation</li> </ul>
<input type="radio"/>	<input type="radio"/>	3. Frame number	<ul style="list-style-type: none"> <li>• Check that the frame number is the same as the number in the following places:               <ul style="list-style-type: none"> <li>o On the order papers</li> <li>o In the engraving on the right chain stay (ST1 side / ST2 underside)</li> <li>o On the manufacturer's plate in the battery box</li> <li>o On the registration document or COC (except ST1 M25)</li> </ul> </li> </ul>
<input type="radio"/>	<input type="radio"/>	3. Final assembly	<ul style="list-style-type: none"> <li>• Straighten handlebar and fix in place with torque wrench</li> <li>• Fit pedals</li> </ul>
<input type="radio"/>	<input type="radio"/>	4. Battery	<ul style="list-style-type: none"> <li>• Make sure rechargeable battery serial number is recorded in the Stromer portal (ST1)</li> <li>• Charge the battery &gt; 80%</li> </ul>
<input type="radio"/>	<input type="radio"/>	5. Tire pressure	<ul style="list-style-type: none"> <li>• Check that the tire pressure is 2.5 bar (facilitates damping features)</li> </ul>
<input type="radio"/>	<input type="radio"/>	6. Brakes	<ul style="list-style-type: none"> <li>• Check brakes:               <ul style="list-style-type: none"> <li>o 6 Nm tightening torque for brake calipers</li> <li>o 4 Nm tightening torque for screws on front brake disk</li> <li>o 20 Nm tightening torque for screws on rear brake disk</li> </ul> </li> </ul>
<input type="radio"/>	<input type="radio"/>	7. Gears	<ul style="list-style-type: none"> <li>• Check gear shift assembly:               <ul style="list-style-type: none"> <li>o Check that all the gears are working</li> <li>o Check that the front derailleur top and bottom limit stops are set</li> <li>o Check that the chain is not touching the front derailleur in the highest and lowest gear</li> </ul> </li> </ul>
<input type="radio"/>	<input type="radio"/>	8. Axle/thru axles	<ul style="list-style-type: none"> <li>• Check thru axles               <ul style="list-style-type: none"> <li>o 20 Nm tightening torque for front wheel (ST1 &amp; ST2)</li> <li>o 20 Nm tightening torque for rear wheel (ST2)</li> <li>o 70 Nm tightening torque for rear wheel (ST1)</li> </ul> </li> </ul>
<input type="radio"/>	<input type="radio"/>	9. Display	<ul style="list-style-type: none"> <li>• Check time and change setting if necessary</li> <li>• Check language and change setting if necessary</li> <li>• Check display contrast</li> </ul>
<input type="radio"/>	<input type="radio"/>	10. Electronics & software	<ul style="list-style-type: none"> <li>• Carry out SIT - see Techbook (ST2)</li> <li>• Carry out system test - see Techbook (ST1)</li> </ul>
<input type="radio"/>	<input type="radio"/>	11. Test ride	<ul style="list-style-type: none"> <li>• Carry out final inspection of the following:               <ul style="list-style-type: none"> <li>o Brakes</li> <li>o Gears</li> <li>o Driving gear</li> </ul> </li> </ul>
<input type="radio"/>	<input type="radio"/>	12. Final inspection	<ul style="list-style-type: none"> <li>• Brief visual check &amp; final clean</li> </ul>



# CHECKLIST

## HANDOVER OF PRODUCT TO CUSTOMER

● **ST1** ● **ST2**

	<b>ITEM</b>	<b>CHECKING PROCESS</b>
○ ○	1. Bike activation & data protection	<ul style="list-style-type: none"> <li>• Check whether the bike and customer data are entered correctly in the Stromer portal</li> <li>• Activate the bike in the Stromer portal (the release code is sent to the customer automatically by email)</li> <li>• The applicable data protection provisions must be accepted by the end customer</li> </ul>
○	2. Stromer app	<ul style="list-style-type: none"> <li>• Explain Stromer app and present its range of functions</li> </ul>
○	3. Software update	<ul style="list-style-type: none"> <li>• Future software updates will be transmitted automatically to the bike.</li> </ul>
○ ○	4. Ergonomic Adjustments to suit the rider	<ul style="list-style-type: none"> <li>• Check that the settings are geared to individual customer requirements <ul style="list-style-type: none"> <li>○ Seat height     Saddle incline/saddle position   Handle position</li> <li>○ Adjust air pressure to weight of rider if suspension forks are fitted (optional)</li> </ul> </li> </ul>
○ ○	5. Menu functions	<ul style="list-style-type: none"> <li>• Explain the following functions before the handover of the product. Full details are also given in our model-specific operating instructions: <ul style="list-style-type: none"> <li>○ On/off switch   display   pedal assist levels</li> <li>○ Brake mode/recuperation   boost mode   push assistance</li> <li>○ Anti-theft mode   system information</li> <li>○ Sensor sensitivity (setting as required by customer)</li> </ul> </li> </ul>
○ ○	6. Battery	<ul style="list-style-type: none"> <li>• Give clear instructions on the following points in relation to the battery: <ul style="list-style-type: none"> <li>○ Inserting/removing the battery   charging the battery</li> <li>○ Information on the distance which can be covered depending on the various possible settings (pedal assist level, weight of rider, route conditions)</li> <li>○ Storage of battery when not in use</li> </ul> </li> </ul>
○ ○	7. Care and transport instructions	<ul style="list-style-type: none"> <li>• Draw specific attention to the following points in order to minimize breakdowns: <ul style="list-style-type: none"> <li>○ Service intervals prescribed by the Retailer   cleaning and care instructions</li> <li>○ Transport instructions (e.g. correct way to position the handlebar)</li> </ul> </li> </ul>
○ ○	8. Terms of warranty	<ul style="list-style-type: none"> <li>• Give a brief explanation of our warranty terms and conditions: <ul style="list-style-type: none"> <li>○ Warranty period   exclusion of warranty</li> <li>○ Coverage and expiry of warranty</li> </ul> </li> </ul>
○ ○	9. Response to fault messages	<ul style="list-style-type: none"> <li>• In the event of a fault message, it is generally advisable to restart the Stromer by taking out the battery and reinserting it. If the problem persists, or if there is a mechanical defect in addition to an electronic problem, contact the Retailer for an analysis of the fault</li> </ul>
○ ○	10. Current advice,	<ul style="list-style-type: none"> <li>• Draw the attention of the customer to the fact that full descriptions and updated advice, further information and descriptions further information of our support area models are always available in the support section of our website (<a href="http://www.stromerbike.com">www.stromerbike.com</a>).</li> </ul>
○ ○	12. Safety instructions	<ul style="list-style-type: none"> <li>• Draw attention to the requirement to wear a helmet</li> <li>• Allow time to practice riding off the road   Explain how to get on without putting pressure on the pedals</li> <li>• Explain special traffic rules for S-class pedelecs (fast e-bikes) and pedelecs (ST1 M25)   see approvals in Techbook</li> </ul>
○ ○	13. Product handover	<ul style="list-style-type: none"> <li>• Bike   accessories (parts box)   vehicle documents/COC</li> </ul>





# ST1 TECH

## FACTS

- Fully integrated e-bike system. Battery integrated in the frame, can be changed at the press of a button.
- Recuperation of the braking energy. Means even better range.
- Transmissionless hub motor. No additional wear on the drive and chain. No mechanical losses. Stepless acceleration. Higher efficiency. Power.
- Charge battery: directly in the bike or outside the Stromer.
- Fantastic power development.
- Stromer riding modes: The user can choose from four support stages.
- Individual sensor setting of the Stromer electronics.
- 3 kg lightweight 522 Wh battery (36 V; 14.5 Ah)
- 2-year or 1000 full charge cycle warranty for the Stromer high-tech battery.
- High-quality carbon fork and Schwalbe BigBen tires specially developed for Stromer with optimized shock absorption qualities for the highest ride comfort.



## INTERFACE BETWEEN RIDER AND STROMER. THE ON-BOARD INSTRUMENTS

### Buttons 1

All Stromer functions can be easily enabled by using just three buttons.

### Energy display 2

The Stromer interface shows the battery charge level, the current consumption and the rate of regenerative braking.

### Speedometer 3

The Stromer interface shows the following ride information: Speed, average speed, trip distance, total distance, trip time and time of day.

### Mode 4

The support mode can be selected from four different output modes. In addition, the Stromer has a boost mode (riding mode without pedaling support) and push assistance.

## Setup

Using defined codes, Stromer users can fine tune their own optimal settings.

## Energy consumption

During an average Stromer ride, the Stromer's energy consumption is less than 1 kWh/100 km and is therefore very cost-effective.

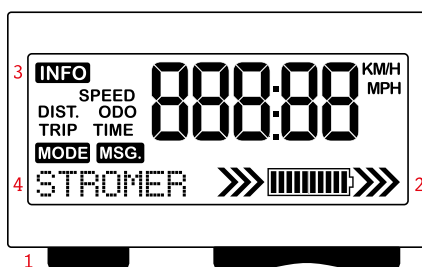

## POWER SYSTEM

The Stromer is powered by the rider and a brushless direct-current motor in the rear hub. A high degree of system efficiency can be achieved because the motor acts directly within the rear hub. The only mechanical contact that occurs within the motor is the industrial ball bearings. The motor is virtually maintenance free.

The Stromer motor is available in three versions:

**Mountain 33** – the climbing specialist

**Power 48** – the powerful, fast model

## ST1 MODELS

### DESIGN

The ST1 is a design masterpiece. At first glance purist and inconspicuously elegant, it modestly conceals its performance with clever details. For example, the battery is integrated elegantly into the down tube, and the motor into the rear hub. Cables are run along the frame, and the form and function of saddle, fenders and carrier are all specifically matched to the design of the ST1.



### RANGE

The ST1 gets you further than you might imagine. Distances of up to 50 miles are not a problem for the battery, which weighs a mere 3 kg and has a capacity of 522 watt-hours. The power pack ingeniously integrated into the frame comes with lithium-ion cells and is child's play to recharge. You can either charge the battery directly in the e-bike or externally at any conventional power socket in the office or at home.

What's more, the ST1 generates energy from the braking process itself, and automatically stores it in the battery.



### POWER

The efficient, silent 500-watt motor accelerates your Stromer with powerful torque from 0 to 30 mph in next to no time. You definitely won't be left trailing at the traffic lights. How much pedal work you do on your e-bike is entirely up to you. You can choose any time between four levels of support directly at the display on the handlebar.



### COMFORT

A Stromer is both a confident and very comfortable way to travel. The balloon tires developed specially for Stromer gently absorb both minor and major bumps in the road, as well as featuring integrated puncture protection and affording excellent grip. The high-caliber Stromerspecific carbon fork also absorbs vibration. The ST1 always combines stability and driving comfort of the highest caliber, so that you always remain fully in control of your e-bike.



## ST1 MODELS

### ST1 MODELS MY15

The ST1 is available in Sport and Comfort versions. In the Sport version, the ST1 comes with either a 20-inch or 17-inch frame. The Comfort version, with its 17-inch frame is easy to climb onto and off thanks to its lower top tube. The ST1 comes in the three colors: white, black or red, and is available optionally with 9-speed or 27-speed gears. A suspension fork and a City Kit exclusively tailored to the typical needs of the Stromer rider can also be

supplied. Whether you want your Stromer for getting to work, transporting items or taking a casual spin through the countryside, with three configurations of motor power you can select just the right Stromer for your individual requirements.

### MOTOR

The brushless, direct-current motor in the rear hub supplies up to 500 watts of power, for effortless acceleration with up to 40 Newton-meters of torque. You can select one of the four different levels of assistance at the display on the handlebar, as required.

**MOUNTAIN 33** – the climbing specialist

**POWER 48** – the powerful, fast model

### MOTOR

	MOUNTAIN 33*	POWER 48*
SUPPORTED SPEED	up to 20 mph	up to 30 mph
OUTPUT	500 W	500 W
TORQUE	40 Nm	30 Nm
RANGE (WITH ST522 BATTERY)**	25–50 miles	25–50 miles

\* Depending on country, insurance and/or a license plate may be required

\*\* 500 W/40 Nm in Switzerland

\*\*\* Sensor sensitivity 30, rider 70 kg

### BATTERY

	ST396	ST522
ENERGY	396 Wh	522 Wh
VOLTAGE	36V	36V
CAPACITY	11 Ah	14.5 Ah
WEIGHT	3 kg	3 kg



# ST1 MODELS

## SPECIFICATIONS ST1

	ELITE	PLATINUM
FORK	Stromer carbon fork	Stromer carbon fork   Opt. SR Suntour Raidon suspension fork
BRAKES	Magura MT2, 180 mm, with integral brake sensor	Magura MT2, 180 mm, with integral brake sensor
GEARSHIFT	Shimano, 9-speed	Shimano, 27-speed
CRANK	42T on Mountain 33   52T on Power 48	50 x 39 x 30T
REAR COGS	11-32T	11-32T
HEADLIGHT	B+M Lumotec IQ Fly/Supernova E3	B+M Lumotec IQ Fly/Supernova E3
REAR LIGHT	B+M Toplight mini	B+M Toplight mini
FENDERS	Stromer custom alloy	Stromer custom alloy
CARRIERS	Stromer custom Racktime	Stromer custom Racktime
TIRES	Stromer custom Schwalbe BigBen 26X2.15	Stromer custom Schwalbe BigBen 26X2.15
SADDLE	Stromer custom ST1	Stromer custom ST1

## GEOMETRY

	MODELL	A	B	C	D	E	F	G	H
up to 178 CM	Sport 17"	420	585	205	74.5	70	425	415	57
above 175 CM	Sport 20"	508	585	205	74.5	70	425	415	57
up to 175 CM	Comfort 17"	420	580	235	74.5	70	425	415	57

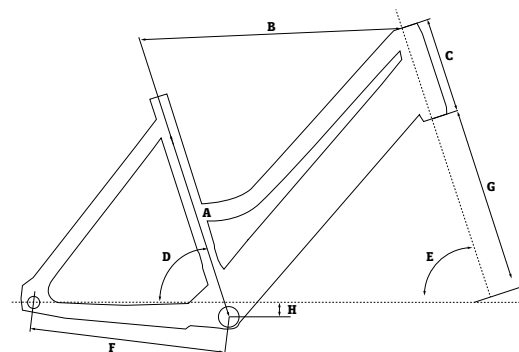
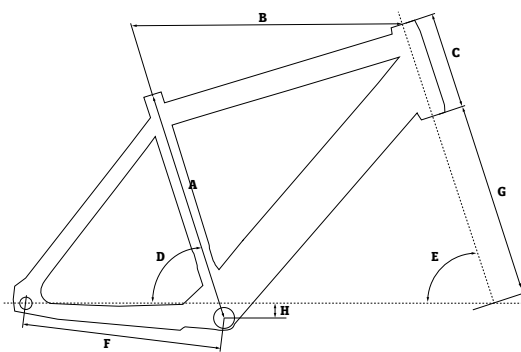

## ST1 S | ST1 T

### ST1 T

The ST1 T with stylish brown finish is available with a 17 or 20-inch sport frame. Equipped with the ingenious Speed Drive by Schlumpf system, it delivers a very special driving experience. A quick kick with the heel, whether at a standstill or while on the move, is sufficient for the gear unit to change the entire ratio. The gear system equipped with Schlumpf Speed Drive consequently has 18 genuine gears without overlaps.

The absence of two chainrings makes the Stromer even more efficient and assures a neat, tidy look and reduced maintenance. The Schwalbe Big Ben tires specially developed for Stromer give the ST1 T a more stable driving feel, combined with ideal shock absorption. To ensure you can confidently and swiftly come to a standstill, even from higher speeds, the ST1 T is fitted with hydraulic Tektro Dorado disc brakes. For better visibility, it has the sturdy and powerful Supernova E3 lighting system. An elegant carrier means you can also easily carry all sorts of loads on the ST1 T.



### ST1 S









The ST1 S, in a sporty green finish, is available with a 17 or 20-inch sport frame and also benefits fully from the driving comfort of the 18-gear Speed Drive by Schlumpf system. Compared to the ST1 T, the single chainring with 32 teeth increases the ratio, delivering an even more sporty ride.

The ST1 S is fitted with Continental Top Contact II tires that make the Stromer even more efficient and agile thanks to their very light weight and lower rolling resistance. Other ingredients for a sporty riding style are the hydraulic Tektro Dorado disc brakes and Supernova E3 lighting system, which makes sure you can see and be seen clearly. The special Stromer sport saddle completes the sporty specification of the ST1 S.



# ST1 PRODUCT OFFERINGS

**ST1****ST1<sup>T</sup>****ST1<sup>S</sup>**

FRAME COLORS			
<b>FORK</b>	Stromer ST1 carbon fork	Stromer ST1 carbon fork	Stromer ST1 carbon fork
<b>BRAKES</b>	Tektro Dorado	Tektro Dorado	Tektro Dorado
<b>GEARSHIFT</b>	Shimano, 27-gear	Shimano XT   Schlumpf Speed Drive   18-gear	Shimano XT   Schlumpf Speed Drive   18-gear
<b>CRANK</b>	50x39x30T	Schlumpf   Speed Drive 30T	Schlumpf   Speed Drive 32T
<b>REAR COGS</b>	11–32T   9-Speed	11–32T   9-Speed	11–32T   9-Speed
<b>HEADLIGHT</b>	B+M Lumotec IQ Fly	Supernova   E3 E-Bike	Supernova   E3 E-Bike
<b>REAR LIGHT</b>	B+M Toplight mini	B+M Toplight mini	B+M Toplight mini
<b>DAYTIME RUNNING LIGHT</b>	–	–	–
<b>FENDERS</b>	Stromer custom aluminum	Stromer custom aluminum	Stromer custom aluminum
<b>CARRIERS</b>	Stromer custom Racktime	Stromer custom Racktime Sytsem	–
<b>TIRES</b>	Stromer custom Schwalbe Big Ben 26X2.15	Stromer custom Schwalbe Big Ben 26x2.15	Continental Top Contact II   26x2.0
<b>SADDLE</b>	Stromer custom Comfort	Stromer custom Comfort	Stromer custom Sport
<b>MOTOR</b>	POWER 48*	POWER 48*	POWER 48*
SUPPORTED SPEED	up to 30 mph	up to 30 mph	up to 30 mph
OUTPUT	500 W	500 W	500 W
TORQUE	30 Nm	30 Nm	30 Nm
RANGE	25–50 miles	25–50 miles	25–50 miles
<b>BATTERY</b>	ST522	ST522	ST522
ENERGY	522 Wh	522 Wh	522 Wh
VOLTAGE	36 V	36 V	36 V
WEIGHT	3 kg	3 kg	3 kg
<b>FRAME SIZE</b>	 <178 cm = Comfort 17"	 <178 cm = Sport 17"	 <178 cm = Sport 17"
		 >175 cm = Sport 20"	 >175 cm = Sport 20"













\* may require insurance and a license plate, depending on country

# ST1 | V1 SPARE PARTS USD

Spare Parts V1 & ST1			
29/4/2016			
USA			
Mechanical drive parts			
	<p>Stromer Art. # <b>213482</b></p> <p>Crank Assembly Lasco 52T ST1 Elite P48</p> <p>WSP USD 45.00 MSRP USD 80.00</p>		<p>Stromer Art. # <b>213483</b></p> <p>Chainring Lasco 3/32 x 52T ST1 Elite P48</p> <p>WSP USD 8.00 MSRP USD 16.00</p>
	<p>Stromer Art. # <b>213484</b></p> <p>Crank Assembly Lasco 42T ST1 Elite M25 &amp; M33</p> <p>WSP USD 45.00 MSRP USD 80.00</p>		<p>Stromer Art. # <b>213485</b></p> <p>Chainring Lasco 3/32 x 42T ST1 Elite M25 &amp; M33</p> <p>WSP USD 8.00 MSRP USD 16.00</p>
	<p>Stromer Art. # <b>213624</b></p> <p>Crank Assembly Triple 50/39/30T ST1 Platinum</p> <p>WSP USD 85.00 MSRP USD 150.00</p>		<p>Stromer Art. # <b>215896</b></p> <p>Chain Guard All V1 &amp; ST1 Platinum</p> <p>WSP USD 11.00 MSRP USD 22.00</p>
	<p>Stromer Art. # <b>215886</b></p> <p>Bottom Bracket All V1 &amp; ST1</p> <p>WSP USD 20.00 MSRP USD 40.00</p>		<p>Stromer Art. # <b>219072</b></p> <p>Bottom Bracket black washer All ST1</p> <p>WSP USD 1.00 MSRP USD 2.00</p>
	<p>Stromer Art. # <b>216933</b></p> <p>Freewheel SunRace 9-spd 11-32t All V1 &amp; ST1</p> <p>includes 3.5mm spacer</p> <p>WSP USD 50.00 MSRP USD 90.00</p>		<p>Stromer Art. # <b>216205</b></p> <p>Crank Assembly FSA Triple 52/39/30T V1</p> <p>WSP USD 85.00 MSRP USD 150.00</p>
	<p>Stromer Art. # <b>400301</b></p> <p>Schlumpf Speed Drive BB Assembly ST1 S with silver pressure plates</p> <p>includes 32T ring and guards</p> <p>WSP USD 800.00 MSRP USD 1200.00</p>		<p>Stromer Art. # <b>400302</b></p> <p>Schlumpf Speed Drive BB Assembly ST1 T with black pressure plates</p> <p>includes 30T ring and guards</p> <p>WSP USD 800.00 MSRP USD 1200.00</p>
	<p>Stromer Art. # <b>400303</b></p> <p>Schlumpf Crank Arm Left ST1 S &amp; ST1 T 170mm crank arm length</p> <p>WSP USD 50.00 MSRP USD 90.00</p>		<p>Stromer Art. # <b>400304</b></p> <p>Schlumpf Crank Arm Right ST1 S &amp; ST1 T 170mm crank arm length</p> <p>WSP USD 50.00 MSRP USD 90.00</p>















**ST1 | V1 SPARE PARTS USD**

	<p>Stromer Art. # <b>400305</b></p> <p>Schlumpf Speed Drive Kickplates, pair ST1 S &amp; ST1 T for 170mm crank arms only</p> <p>WSP USD 55.00 MSRP USD 100.00</p>		<p>Stromer Art. # <b>400307</b></p> <p>Schlumpf Speed Drive Chainring 30T ST1 T</p> <p>WSP USD 26.00 MSRP USD 52.00</p>
	<p>Stromer Art. # <b>400306</b></p> <p>Schlumpf Speed Drive Chainring 32T ST1 S</p> <p>WSP USD 26.00 MSRP USD 52.00</p>		<p>Stromer Art. # <b>400434</b></p> <p>Schlumpf Speed Drive Guard 28-30T ST1 S</p> <p>WSP USD 32.00 MSRP USD 64.00</p>
	<p>Stromer Art. # <b>400435</b></p> <p>Schlumpf Speed Drive Guard 32-34T ST1 T</p> <p>WSP USD 32.00 MSRP USD 64.00</p>		<p>Stromer Art. # <b>400308</b></p> <p>Schlumpf Tool Set ST1 S &amp; ST1 T</p> <p>WSP USD 60.00 MSRP USD 100.00</p>
	<p>Stromer Art. # <b>400309</b></p> <p>Schlumpf Torque Screwdriver ST1 S &amp; ST1 T</p> <p>including 1.5mm bit (400322)</p> <p>WSP USD 115.00 MSRP USD 200.00</p>		<p>Stromer Art. # <b>400322</b></p> <p>Schlumpf Replacement Bit, 1.5mm ST1 S &amp; ST1 T</p> <p>fits 400309</p> <p>WSP USD 12.00 MSRP USD 24.00</p>
<b>Battery</b>			
	<p>Stromer Art. # <b>213434</b></p> <p>Battery Assembly ST522 14.5Ah All V1 &amp; ST1</p> <p>WSP USD 499.00 MSRP USD 760.00</p>		
<b>Brake</b>			
	<p>Stromer Art. # <b>213492</b></p> <p>Brake Magura MT2e front ST1 To be replaced by 400263</p> <p>includes rotor &amp; mounting bolts</p> <p>WSP USD 140.00 MSRP USD 240.00</p>		<p>Stromer Art. # <b>213493</b></p> <p>Brake Magura MT2e rear ST1 To be replaced by 400264</p> <p>includes rotor &amp; mounting bolts</p> <p>WSP USD 150.00 MSRP USD 250.00</p>
	<p>Stromer Art. # <b>400263</b></p> <p>Tektro Dorado HD-E715 brake front ST1, ST1 T &amp; ST1 S Without sensor switch</p> <p>includes rotor &amp; mounting bolts</p> <p>WSP USD 90.00 MSRP USD 155.00</p>		<p>Stromer Art. # <b>400264</b></p> <p>Tektro Dorado HD-E715 brake rear ST1, ST1 T &amp; ST1 S With sensor switch</p> <p>includes rotor &amp; mounting bolts</p> <p>WSP USD 95.00 MSRP USD 165.00</p>















# ST1 | V1 SPARE PARTS USD

	<p>Stromer Art. # <b>400265</b></p> <p>Brake Pads Tektro E10.11 (soft) ST1, ST1 T &amp; ST1 S Standard, low noise</p> <p>WSP USD 8.00 MSRP USD 16.00</p>		<p>Stromer Art. # <b>400266</b></p> <p>Brake Pads Tektro P20.11 (hard) ST1, ST1 T &amp; ST1 S Optional, high performance</p> <p>WSP USD 8.00 MSRP USD 16.00</p>
	<p>Stromer Art. # <b>400267</b></p> <p>Brake Service Kit Tektro ST1, ST1 T &amp; ST1 S</p> <p>WSP USD 8.00 MSRP USD 16.00</p>		<p>Stromer Art. # <b>400268</b></p> <p>Brake Rotor Tektro TR180-1 ST1, ST1 T &amp; ST1 S</p> <p>includes mounting bolts</p> <p>WSP USD 15.00 MSRP USD 30.00</p>
	<p>Stromer Art. # <b>215567</b></p> <p>Brake Pads Magura 7.2, pair ST1 &amp; ST2</p> <p>WSP USD 22.00 MSRP USD 44.00</p>		
<b>Fork</b>			
	<p>Stromer Art. # <b>400233</b></p> <p>Fork Kit Carbon red 340mm ST1</p> <p>incl axle, compressor, cable guides</p> <p>WSP USD 340.00 MSRP USD 520.00</p>		<p>Stromer Art. # <b>400241</b></p> <p>Fork Kit SR red 300mm ST1</p> <p>incl axle, compressor, cable guide</p> <p>WSP USD 265.00 MSRP USD 450.00</p>
	<p>Stromer Art. # <b>400238</b></p> <p>Fork Kit Carbon white 340mm ST1</p> <p>incl axle, compressor, cable guides</p> <p>WSP USD 340.00 MSRP USD 520.00</p>		<p>Stromer Art. # <b>400242</b></p> <p>Fork Kit SR white 300mm ST1</p> <p>incl axle, compressor, cable guide</p> <p>WSP USD 265.00 MSRP USD 450.00</p>
	<p>Stromer Art. # <b>400239</b></p> <p>Fork Kit Carbon black 340mm ST1</p> <p>incl axle, compressor, cable guides</p> <p>WSP USD 340.00 MSRP USD 520.00</p>		<p>Stromer Art. # <b>400244</b></p> <p>Fork Kit SR black 300mm ST1</p> <p>incl axle, compressor, cable guide</p> <p>WSP USD 265.00 MSRP USD 450.00</p>
	<p>Stromer Art. # <b>400339</b></p> <p>Fork blue ST1 LE 340mm steerer tube</p> <p>incl axle, compressor, inserts &amp; guides</p> <p>WSP USD 340.00 MSRP USD 520.00</p>		<p>Stromer Art. # <b>400342</b></p> <p>Fork green ST1 S 340mm steerer tube</p> <p>incl axle, compressor, inserts &amp; guides</p> <p>WSP USD 340.00 MSRP USD 520.00</p>

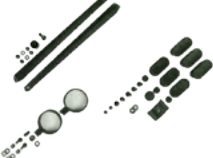

# ST1 | V1 SPARE PARTS USD

	<p>Stromer Art. # <b>400344</b></p> <p>Fork brown ST1 T 340mm steerer tube</p> <p>incl axle, compressor, inserts &amp; guides</p> <p>WSP USD 340.00 MSRP USD 520.00</p>		<p>Stromer Art. # <b>215730</b></p> <p>Insert for Brake mounting All ST1 and ST2 with carbon forks One piece, fits carbon fork</p> <p>WSP USD 2.00 MSRP USD 4.00</p>
	<p>Stromer Art. # <b>221243</b></p> <p>Front axle All ST1 and ST2 with carbon fork</p> <p>WSP USD 20.00 MSRP USD 40.00</p>		<p>Stromer Art. # <b>215872</b></p> <p>Fork rigid 300mm V1 White</p> <p>WSP USD 120.00 MSRP USD 200.00</p>
	<p>Stromer Art. # <b>215873</b></p> <p>Fork rigid 300mm V1 Black</p> <p>WSP USD 120.00 MSRP USD 200.00</p>		<p>Stromer Art. # <b>215871</b></p> <p>Fork rigid 300mm V1 Red</p> <p>WSP USD 120.00 MSRP USD 200.00</p>
	<p>Stromer Art. # <b>400170</b></p> <p>Cable Guides for Front Fork ST1, ST1 S &amp; ST1 T</p> <p>Includes bolts and washers</p> <p>WSP USD 3.00 MSRP USD 6.00</p>		
<b>Fender / Carrier</b>			
	<p>Stromer Art. # <b>219202</b></p> <p>Fender Kit - front for rigid fork ST1 &amp; ST2 with carbon forks</p> <p>WSP USD 40.00 MSRP USD 80.00</p>		<p>Stromer Art. # <b>219201</b></p> <p>Fender Kit - front for suspension fork ST1 &amp; ST2 with SR Suntour forks</p> <p>WSP USD 50.00 MSRP USD 90.00</p>
	<p>Stromer Art. # <b>219204</b></p> <p>Fender parts - rear 17 &amp; 22 no plate ST1 &amp; ST2 No plate holder, for USA &amp; ST1 M25</p> <p>assembly requires 213518</p> <p>WSP USD 45.00 MSRP USD 80.00</p>		<p>Stromer Art. # <b>219205</b></p> <p>Fender stays - no rear carrier ST1</p> <p>incl plate holder, stays and bolts</p> <p>WSP USD 15.00 MSRP USD 30.00</p>
	<p>Stromer Art. # <b>213500</b></p> <p>Fender end cap - no plate holder ST1 &amp; ST2</p> <p>WSP USD 3.00 MSRP USD 6.00</p>		<p>Stromer Art. # <b>219206</b></p> <p>Fender - spare parts kit ST1 &amp; ST2</p> <p>WSP USD 15.00 MSRP USD 30.00</p>





# ST1 | V1 SPARE PARTS USD

	Stromer Art. #	<b>213518</b>
	Carrier Stromer ST1 ST1 & ST1 T	
	WSP	USD 35.00
	MSRP	USD 70.00

**Cable / Controller**

	Stromer Art. #	<b>213415</b>
	TMM Sensor Cable incl. Connector TS All V1 & ST1	
	WSP	USD 10.00
	MSRP	USD 20.00

	Stromer Art. #	<b>213425</b>
	Wicket Cable All V1 & ST1	
	without bolts	
	WSP	USD 25.00
	MSRP	USD 50.00

	Stromer Art. #	<b>213426</b>
	Charging Socket All V1 & ST1	
	WSP	USD 10.00
	MSRP	USD 20.00

	Stromer Art. #	<b>213427</b>
	Display Cable extension All V1 & ST1 (except MY16 EU) For headlights with switch	
	Use with 213515 & 219486	
	WSP	USD 15.00
	MSRP	USD 30.00

	Stromer Art. #	<b>213608</b>
	Power Cable (3-Pin) All V1 & ST1	
	WSP	USD 16.00
	MSRP	USD 32.00

	Stromer Art. #	<b>219167</b>
	Light Y-Cable Frame All ST1, except MY16 for EU For headlights with switch	
	Use with 213515 & 219486	
	WSP	USD 5.00
	MSRP	USD 10.00

**Charger**

	Stromer Art. #	<b>219041</b>
	Battery Charger ST1 All V1 & ST1 US only	
	includes charger & power adaptor	
	WSP	USD 85.00
	MSRP	USD 125.00

	Stromer Art. #	<b>213438</b>
	Charger Adapter All V1 & ST1	
	WSP	USD 16.00
	MSRP	USD 32.00

**Light**

	Stromer Art. #	<b>219486</b>
	Light Front Supernova E3 30-43V All ST1 With switch	
	without holder incl Cable & plug	
	WSP	USD 140.00
	MSRP	USD 250.00















	Stromer Art. #	<b>213515</b>
	Light Front B+M Lumotec IQ Fly E 42/6V All ST1 With switch	
	incl. Holder carbon fork, Cable & plug	
	WSP	USD 80.00
	MSRP	USD 140.00

	Stromer Art. #	<b>213550</b>
	Light Holder Supernova All ST1 Carbon fork	
	WSP	USD 10.00
	MSRP	USD 20.00

	Stromer Art. #	<b>213551</b>
	Light Holder Supernova All ST1 Suntour fork	
	WSP	USD 10.00
	MSRP	USD 20.00



**ST1 | V1 SPARE PARTS USD**

	<p>Stromer Art. # <b>213517</b></p> <p>Light rear B+M Toplight Mini ST2</p> <p>incl. Cable &amp; plug</p> <p>WSP USD 20.00 MSRP USD 40.00</p>		<p>Stromer Art. # <b>213547</b></p> <p>Light Holder B+M Adapter All ST1 Suntour fork</p> <p>WSP USD 3.00 MSRP USD 6.00</p>
<b>Cockpit</b>			
	<p>Stromer Art. # <b>221352</b></p> <p>Saddle Sport ST1 S &amp; ST2 Sport</p> <p>WSP USD 25.00 MSRP USD 50.00</p>		<p>Stromer Art. # <b>400249</b></p> <p>Saddle Comfort ST1, ST1 T &amp; ST2 Comfort</p> <p>WSP USD 25.00 MSRP USD 50.00</p>
	<p>Stromer Art. # <b>213614</b></p> <p>Saddle VL-1205 Stromer Sport All V1 &amp; ST1</p> <p>WSP USD 20.00 MSRP USD 40.00</p>		<p>Stromer Art. # <b>213445</b></p> <p>Saddle VL-4190 Stromer Comfort All V1 &amp; ST1</p> <p>WSP USD 20.00 MSRP USD 40.00</p>
	<p>Stromer Art. # <b>400334</b></p> <p>Handlebar flat All ST2 &amp; ST1 S</p> <p>WSP USD 20.00 MSRP USD 40.00</p>		<p>Stromer Art. # <b>400259</b></p> <p>Handlebar 20mm rise Optional for all ST1 &amp; ST2 20 degree backsweep</p> <p>WSP USD 20.00 MSRP USD 40.00</p>
	<p>Stromer Art. # <b>213612</b></p> <p>Seat Post 17", JD-SP61, 350mm All V1, ST1 &amp; ST2</p> <p>WSP USD 23.00 MSRP USD 46.00</p>		<p>Stromer Art. # <b>213613</b></p> <p>Seat Post 20", JD-SP61, 400mm All V1, ST1 &amp; ST2</p> <p>WSP USD 23.00 MSRP USD 46.00</p>
	<p>Stromer Art. # <b>400252</b></p> <p>Seat Post 17", JD-SP100, 350mm ST1 T, ST1 S, ST2 &amp; ST2 S</p> <p>WSP USD 23.00 MSRP USD 46.00</p>		<p>Stromer Art. # <b>400253</b></p> <p>Seat Post 20" &amp; 22", JD-SP100, 400mm ST1 T, ST1 S, ST2 &amp; ST2 S</p> <p>WSP USD 23.00 MSRP USD 46.00</p>
	<p>Stromer Art. # <b>400258</b></p> <p>Grips Ergon GS1-L Black SP Kit ST1 S, ST2 &amp; ST2 S</p> <p>WSP USD 20.00 MSRP USD 40.00</p>		<p>Stromer Art. # <b>219376</b></p> <p>Bell Nuvo NH-B45AP black All</p> <p>WSP USD 3.00 MSRP USD 6.00</p>

# ST1 | V1 SPARE PARTS USD

	<p>Stromer Art. # <b>213603</b></p> <p>Grip Velo Ergo VLG-690AD2 , 135mm All V1 &amp; ST1</p> <p>WSP USD 10.00 MSRP USD 20.00</p>		<p>Stromer Art. # <b>213462</b></p> <p>Grip Velo Rip VLG 331A black All V1 &amp; ST1</p> <p>WSP USD 10.00 MSRP USD 20.00</p>
	<p>Stromer Art. # <b>222233</b></p> <p>Dropper Seat Post, JD-YSP01, 400mm Optional for all ST1 &amp; ST2</p> <p>WSP USD 105.00 MSRP USD 175.00</p>		
<b>Wheel</b>			
	<p>Stromer Art. # <b>213467</b></p> <p>Alex Rims FR30 rim front ST1, ST1 T, ST1 S &amp; ST2</p> <p>WSP USD 25.00 MSRP USD 50.00</p>		<p>Stromer Art. # <b>213471</b></p> <p>Alex Rims FR30 rim rear ST1, ST1 T, ST1 S &amp; ST2</p> <p>With asymmetrical hole drilling</p> <p>WSP USD 30.00 MSRP USD 60.00</p>
	<p>Stromer Art. # <b>400338</b></p> <p>Alex Rims FR30 rim front ST1 LE With silver +STROMER- logos</p> <p>WSP USD 35.00 MSRP USD 70.00</p>		<p>Stromer Art. # <b>400337</b></p> <p>Alex Rims FR30 rim rear ST1 LE With silver +STROMER- logos</p> <p>With asymmetrical hole drilling</p> <p>WSP USD 40.00 MSRP USD 80.00</p>
	<p>Stromer Art. # <b>213619</b></p> <p>Tire Schwalbe BigBen Stromer ST2</p> <p>WSP USD 25.00 MSRP USD 50.00</p>		<p>Stromer Art. # <b>215949</b></p> <p>Motor Accessories Nut and Spacer Kit All ST1</p> <p>WSP USD 15.00 MSRP USD 30.00</p>
	<p>Stromer Art. # <b>213622</b></p> <p>Rear Wheel Assembly M33, new Silver spokes</p> <p>incl. freewheel, rotor, tire, tube &amp; rim strip</p> <p>WSP USD 1050.00 MSRP USD 1520.00</p>		<p>Stromer Art. # <b>213623</b></p> <p>Rear Wheel Assembly P48, new All ST1 Silver spokes</p> <p>incl. freewheel, rotor, tire, tube &amp; rim strip</p> <p>WSP USD 1050.00 MSRP USD 1520.00</p>
	<p>Stromer Art. # <b>400413</b></p> <p>Rear Wheel Assembly P48, new ST1, ST1 S &amp; ST1 T With black spokes</p> <p>incl. freewheel, rotor, tire, tube &amp; rim strip</p> <p>WSP USD 1050.00 MSRP USD 1520.00</p>		<p>Stromer Art. # <b>400311</b></p> <p>Rim Tape Herrmans HPP 559x26 ST2, ST1, ST1 LE, ST1 S, ST1 T</p> <p>use with Alex FR30 rim</p> <p>WSP USD 3.00 MSRP USD 6.00</p>













# ST1 | V1 SPARE PARTS USD

	<p>Stromer Art. # <b>400428</b></p> <p>Hub Front Formula DC71 Gloss Black ST1, ST1 LE, ST1 T, ST1 S &amp; ST2 36 hole</p> <p>WSP USD 35.00 MSRP USD 70.00</p>		<p>Stromer Art. # <b>400429</b></p> <p>Hub Bearings DT Swiss, 18x30x7mm, pair All ST1 &amp; ST2 Original for ST2 S front hub</p> <p>Upgrade for Formula DC71 front hubs</p> <p>WSP USD 28.00 MSRP USD 56.00</p>
	<p>Stromer Art. # <b>400423</b></p> <p>Spoke Kit ST1 &amp; ST2 Front Left Silver ST1, ST1 LE &amp; ST2 20 spokes &amp; nipples</p> <p>use with Alex FR30 rim</p> <p>WSP USD 18.00 MSRP USD 36.00</p>		<p>Stromer Art. # <b>400424</b></p> <p>Spoke Kit ST1 &amp; ST2 Front Right Silver ST1, ST1 LE &amp; ST2 20 spokes &amp; nipples</p> <p>use with Alex FR30 rim</p> <p>WSP USD 18.00 MSRP USD 36.00</p>
	<p>Stromer Art. # <b>400362</b></p> <p>Spoke Kit ST1 Rear Left Silver ST1 &amp; ST1 LE 20 spokes &amp; nipples</p> <p>use with Alex FR30 rim</p> <p>WSP USD 15.00 MSRP USD 28.00</p>		<p>Stromer Art. # <b>400363</b></p> <p>Spoke Kit ST1 Rear Right Silver ST1 &amp; ST1 LE 20 spokes &amp; nipples</p> <p>WSP USD 15.00 MSRP USD 28.00</p>
	<p>Stromer Art. # <b>400364</b></p> <p>Spoke Kit ST1 Front Left Black ST1, ST1 T &amp; ST1 S 20 spokes &amp; nipples</p> <p>use with Alex FR30 rim</p> <p>WSP USD 18.00 MSRP USD 36.00</p>		<p>Stromer Art. # <b>400365</b></p> <p>Spoke Kit ST1 Front Right Black ST1, ST1 T &amp; ST1 S 20 spokes &amp; nipples</p> <p>use with Alex FR30 rim</p> <p>WSP USD 18.00 MSRP USD 36.00</p>
	<p>Stromer Art. # <b>400366</b></p> <p>Spoke Kit ST1 Rear Left Black ST1, ST1 T &amp; ST1 S 20 spokes &amp; nipples</p> <p>use with Alex FR30 rim</p> <p>WSP USD 18.00 MSRP USD 36.00</p>		<p>Stromer Art. # <b>400367</b></p> <p>Spoke Kit ST1 Rear Right Black ST1, ST1 T &amp; ST1 S 20 spokes &amp; nipples</p> <p>use with Alex FR30 rim</p> <p>WSP USD 18.00 MSRP USD 36.00</p>
<b>Display</b>			
	<p>Stromer Art. # <b>215738</b></p> <p>Stromer Display V1.1 All V1</p> <p>WSP USD 169.00 MSRP USD 240.00</p>		<p>Stromer Art. # <b>213609</b></p> <p>Stromer Display ST1 All ST1</p> <p>WSP USD 85.00 MSRP USD 150.00</p>
	<p>Stromer Art. # <b>213430</b></p> <p>Display Housing Clamp All V1 &amp; ST1</p> <p>WSP USD 3.00 MSRP USD 6.00</p>		



# ST1 | V1 SPARE PARTS USD

Torque Sensor TMM			
	<p>Stromer Art. # <b>213414</b></p> <p>TMM Sensor ID Bike V2.0 ST1 All ST1</p> <p>WSP USD 50.00 MSRP USD 90.00</p>		<p>Stromer Art. # <b>215950</b></p> <p>TMM Sensor Cover KIT All ST1</p> <p>WSP USD 5.00 MSRP USD 10.00</p>
	<p>Stromer Art. # <b>218472</b></p> <p>TMM Sensor Plate Dropout ST1 Kit All ST1</p> <p>includes bolts</p> <p>WSP USD 30.00 MSRP USD 60.00</p>		<p>Stromer Art. # <b>213415</b></p> <p>TMM Sensor Cable incl. Connector TS All V1 &amp; ST1</p> <p>WSP USD 10.00 MSRP USD 20.00</p>
Frame			
	<p>Stromer Art. # <b>213416</b></p> <p>Wicket red All ST1</p> <p>WSP USD 95.00 MSRP USD 170.00</p>		<p>Stromer Art. # <b>213417</b></p> <p>Wicket white All ST1</p> <p>WSP USD 95.00 MSRP USD 170.00</p>
	<p>Stromer Art. # <b>213418</b></p> <p>Wicket black All ST1</p> <p>WSP USD 95.00 MSRP USD 170.00</p>		<p>Stromer Art. # <b>215862</b></p> <p>Wicket Joint All ST1</p> <p>WSP USD 5.00 MSRP USD 10.00</p>
	<p>Stromer Art. # <b>400340</b></p> <p>Wicket blue ST1 LE</p> <p>WSP USD 95.00 MSRP USD 170.00</p>		<p>Stromer Art. # <b>400341</b></p> <p>Wicket green ST1 S</p> <p>WSP USD 95.00 MSRP USD 170.00</p>
	<p>Stromer Art. # <b>400343</b></p> <p>Wicket brown ST1 T</p> <p>WSP USD 95.00 MSRP USD 170.00</p>		<p>Stromer Art. # <b>215875</b></p> <p>Hinge Bolt All ST1</p> <p>WSP USD 8.00 MSRP USD 16.00</p>
	<p>Stromer Art. # <b>215947</b></p> <p>Wicket Lock Kit All ST1</p> <p>WSP USD 32.00 MSRP USD 64.00</p>		<p>Stromer Art. # <b>215948</b></p> <p>Battery Eject Button Kit All ST1</p> <p>WSP USD 5.00 MSRP USD 10.00</p>



**ST1 | V1 SPARE PARTS USD**

	<p>Stromer Art. # <b>219236</b></p> <p>Headset Crown Race VP J304AC All ST2, All ST1 For SR Suntour suspension</p> <p>fits 219253 and 221346</p> <p>WSP USD 5.00 MSRP USD 10.00</p>		<p>Stromer Art. # <b>219253</b></p> <p>Headset VP J304AC ST1 Rigid &amp; SR Suntour forks</p> <p>includes crown race for SR fork</p> <p>WSP USD 25.00 MSRP USD 50.00</p>
Picture not yet available	<p>Stromer Art. # <b>221346</b></p> <p>Headset ST1 LE, ST1 T, ST1 S, ST2 &amp; ST2 S now also includes 400257</p> <p>no crown race for SR fork</p> <p>WSP USD 25.00 MSRP USD 50.00</p>		<p>Stromer Art. # <b>400074</b></p> <p>Headset Spacer, 10mm ST1 LE, ST1 T, ST1 S, ST2 &amp; ST2 S</p> <p>WSP USD 1.00 MSRP USD 2.00</p>
	<p>Stromer Art. # <b>213447</b></p> <p>Spacer VP 1-1/8 10mm ST1</p> <p>WSP USD 1.00 MSRP USD 2.00</p>		<p>Stromer Art. # <b>213448</b></p> <p>Spacer VP 1-1/8 5mm ST1</p> <p>WSP USD 1.00 MSRP USD 2.00</p>
	<p>Stromer Art. # <b>215548</b></p> <p>Topcap and compressor ST1</p> <p>WSP USD 10.00 MSRP USD 20.00</p>	Picture not yet available	<p>Stromer Art. # <b>221339</b></p> <p>Topcap and compressor ST1 LE, ST1 T, ST1 S, ST2 &amp; ST2 S</p> <p>WSP USD 8.00 MSRP USD 16.00</p>
	<p>Stromer Art. # <b>213513</b></p> <p>CS Guard left Neoprene All ST1</p> <p>WSP USD 5.00 MSRP USD 10.00</p>		<p>Stromer Art. # <b>213514</b></p> <p>CS Guard right Neoprene All ST1</p> <p>WSP USD 5.00 MSRP USD 10.00</p>
	<p>Stromer Art. # <b>216209</b></p> <p>Frame BB Rubber Plug for Cables All ST1</p> <p>WSP USD 3.00 MSRP USD 6.00</p>		<p>Stromer Art. # <b>215890</b></p> <p>Cable Guide All ST1</p> <p>WSP USD 10.00 MSRP USD 20.00</p>
	<p>Stromer Art. # <b>216210</b></p> <p>Frame plug bolt fender ST2 &amp; ST2 S</p> <p>WSP USD 3.00 MSRP USD 6.00</p>		<p>Stromer Art. # <b>400168</b></p> <p>Kickstand no return spring ST1 ST1, ST1 T &amp; ST1 S CH &amp; US Markets</p> <p>incl. Bolt &amp; Washer</p> <p>WSP USD 40.00 MSRP USD 70.00</p>

# ST1 | V1 SPARE PARTS USD

	<p>Stromer Art. # <b>213523</b></p> <p>Trailer Motor Nut Follow Me All ST1 In the EU, only legal for M25</p> <p>WSP USD 25.00 MSRP USD 50.00</p>		<p>Stromer Art. # <b>213522</b></p> <p>Trailer Motor Nut Bob Yak All ST1 In the EU, only legal for M25</p> <p>WSP USD 25.00 MSRP USD 50.00</p>
	<p>Stromer Art. # <b>213521</b></p> <p>Trailer Plate Stromer All ST1 In the EU, only legal for M25</p> <p>Without bolts</p> <p>WSP USD 20.00 MSRP USD 40.00</p>		<p>Stromer Art. # <b>215861</b></p> <p>Adapter Shimano Front Derailleur ST1 Platinum</p> <p>WSP USD 5.00 MSRP USD 10.00</p>
	<p>Stromer Art. # <b>221344</b></p> <p>Touch up paint ST1 &amp; ST2 Black (K720T)</p> <p>WSP USD 5.00 MSRP USD 10.00</p>		<p>Stromer Art. # <b>216361</b></p> <p>Touch-up paint All ST1 Red (R912F)</p> <p>WSP USD 5.00 MSRP USD 10.00</p>
	<p>Stromer Art. # <b>216362</b></p> <p>Touch-up paint All ST1 White (W210I)</p> <p>WSP USD 5.00 MSRP USD 10.00</p>		<p>Stromer Art. # <b>400319</b></p> <p>Touch-up paint ST1 T Brown (C533W)</p> <p>WSP USD 5.00 MSRP USD 10.00</p>
	<p>Stromer Art. # <b>400320</b></p> <p>Touch-up paint ST1 S Green (G357Z)</p> <p>WSP USD 5.00 MSRP USD 10.00</p>		<p>Stromer Art. # <b>400321</b></p> <p>Touch-up paint ST1 LE Blue (YS 7963)</p> <p>WSP USD 5.00 MSRP USD 10.00</p>
	<p>Stromer Art. # <b>215893</b></p> <p>Seat Clamp All ST1</p> <p>WSP USD 10.00 MSRP USD 20.00</p>		
<b>Accessories</b>			
	<p>Stromer Art. # <b>218409</b></p> <p>Programming cable ST1 Kit All ST1</p> <p>WSP EUR 100.00 MSRP USD 60.00</p>		<p>Stromer Art. # <b>216199</b></p> <p>Shorting Plug for ST1 Programming All ST1</p> <p>WSP EUR 6.00 MSRP USD 3.00</p>

## ST1 | V1 SPARE PARTS USD

	<p>Stromer Art. # <b>216173</b></p> <p>ST1 User Manual 5 language All ST1</p> <p>WSP EUR 6.00 MSRP USD 3.00</p>		<p>Stromer Art. # <b>215589</b></p> <p>BMC Group Operating Manual DE/FR All ST1 and ST2</p> <p>WSP EUR 6.00 MSRP USD 3.00</p>
	<p>Stromer Art. # <b>215590</b></p> <p>BMC Group Operating Manual EN/SP All ST1 and ST2</p> <p>WSP EUR 6.00 MSRP USD 3.00</p>		<p>Stromer Art. # <b>215591</b></p> <p>BMC Group Operating Manual IT/NL All ST1 and ST2</p> <p>WSP EUR 6.00 MSRP USD 3.00</p>
	<p>Stromer Art. # <b>400002</b></p> <p>Sticker Stromer Demo Bike Black All Each</p> <p>WSP EUR 6.00 MSRP USD 3.00</p>		

# ST1 SERVICE

## TROUBLESHOOTING

If the following faults and symptoms arise, the relevant component is replaced directly.

### MOTOR:

- The following motor problems are shown on the display as faults:  
ICCURRE, HEAT, OVERHEAT, HALL, CURR, Faseless, BRAKE, Block and TMM (without riding the bike)
- The following symptoms indicate that a technical fault has occurred in the motor:  
Motor falters during travel, motor produces mechanical noises, motor locks.

### DISPLAY:

- For display faults, replace the display with one in the latest version
- Currently, the latest version is 0.88  
(Use the code 2000 when requesting this version)
- Broken display clamps are replaced individually

### REAR COGS:

- For the following faults, we recommend replacement of the rear cogs: gears perform poorly and loud noises are produced

### CHARGER:

- The charger is completely replaced for the following faults:

The charger does not charge (fuse is OK)

The ventilation fan is not working or is making a noise

The charger cannot be switched on (LEDs on charger do not light up)

### FAULT NO\_COM/NO\_BATT (VISIBLE ON DISPLAY):

- 1 Check the battery with a voltmeter. If the battery voltage is 32 V or more, proceed to Step 2.
- 1.1 If the battery voltage is less than 32 V, the battery is deeply discharged.

**IMPORTANT: Reviving the battery invalidates any right to warranty claims!**



- 2 Separate the power cables under the left chain stay and check the battery voltage at the pins shown in the photo. If the voltage obtained agrees with the battery voltage and the display continues to show NO\_COM/NO\_BATT, proceed to Step 3.
- 2.1 If the voltage obtained is less than the battery voltage (+/- 1 V difference), remove the battery cover and check the connections. If the difference remains, check the voltage directly at the wicket cable. Using the voltage obtained at the wicket cable, identify whether the power cable or the wicket cable needs to be replaced.

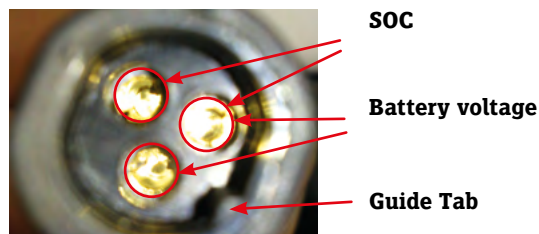

- 3 Separate the TMM sensor cable under the left chain stay (3-pole cable). If the NO\_COM/NO\_BATT fault message disappears from the display, replace the TMM sensor and its cable.

## ST1 SERVICE

### TROUBLESHOOTING

- 3** Separate the TMM sensor cable under the left chain stay (3-pole cable).  
If the NO\_COM/NO\_BATT fault message disappears from the display, replace the TMM sensor and its cable.



- 4** Connect a functioning display directly to the motor.  
If the fault message is still displayed, the motor must be replaced (continue at step 5). If the fault message

disappears, connect the display on the handlebar to the display cable. If the fault message disappears, the display must be replaced. If the fault message is still present, the display cable is faulty.

- 5** The fault could be narrowed down to the motor.  
File a support request via Google Cloud and return the defective motor to Customer Service at myStromer AG.

## ST1 SERVICE

### SOC MEASUREMENT

Check the **Battery Management System** for a fault caused by overvoltage as follows.

- 1** The BMS must be activated before checking the SOC signal (State Of Charge).  
(By giving a boost charge to the battery for approx. 10 seconds or placing it in the Stromer).
- 2** Measure the voltage of the SOC signal (negative terminal <=> SOC pin) using a voltmeter.  
Compare the value obtained with the table below. A variation of +/- 1 V is within the range of tolerance.
- 3** If the value is outside this range of tolerance (+/- 1 V), the BMS is defective.  
In this case, the battery needs to be replaced.

#### 10/11AH

Display	U-Akku	U-SOC
100%	42V	10V
75%	39.5V	8V
50%	37.5V	5V
25%	36V	2V
0%	31V	0V

#### 14.5AH

Display	U-Akku	U-SOC
100%	42V	10V
75%	39V	8V
50%	37V	5V
25%	35.5V	2V
0%	33V	0V



## ST1 SERVICE

### TMM ANALYSIS

To analyse a TMM sensor there are several point to check:

- 1** Visual check
  - a** Connector on the left and right chainstay
  - b** The plastic housing of the sensor should not touch the frame
- 2** Functional test
  - a** Put the Stromer in a workstand and mount the TMM sensor manually (as picture a), the Stromer should work like this:

- i M25 alternating acceleration up to 15 mph
- ii M33 > 26 mph
- iii P48 > 32 mph

If the Stromer fails one of these criteria, the TMM sensor must be replaced.



# ST1 SERVICE PROGRAMMING

**IMPORTANT!**  
**PLEASE OBSERVE THE FOLLOWING POINTS TO ENSURE THAT NO ADDITIONAL DEFECTS ARISE DURING PROGRAMMING:**

- Only use new adapters with a switch for programming cables (see Fig. 3b).

**VERSIONS:**

**IMPORTANT!**  
 Ensure that V8.0 firmware is always installed in the V1.1 display.

VERSIONEN		FIRMWARE V5.3		FIRMWARE V8.0	
		Kontroller V1	Kontroller V1.1	Kontroller V1	Kontroller V1.1
<b>DISPLAY</b>	Stromer V1	OK			
<b>V1</b>	Stromer V1.1	OK			
<b>DISPLAY</b>	Stromer V1			OK	OK
<b>V1.1</b>	Stromer V1.1			OK	OK

**DISPLAY V1**



Figure 1

**DISPLAY V1.1**



Figure 2

**STROMER V1**

Thömus logo on the top tube and head tube

Controller V1  
 2-pole power plug



**STROMER V1.1**

Stromer logo on the top tube and head tube

Controller V1.1  
 3-pole power plug



# ST1 SERVICE

## PROGRAMMING ELEMENTS

**Programming cable (USB to RS232)**



Figure 3

**Programming switch V1.0 (on)**



Figure 4

**Programming plug open**



Figure 5

**Programming plug closed**

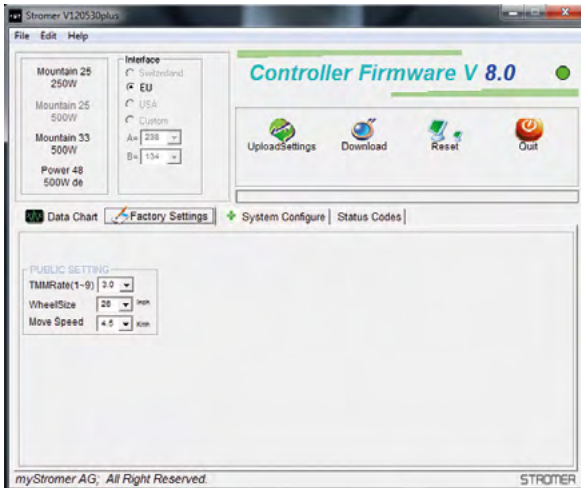
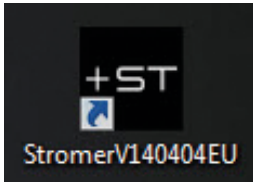

Figure 6

# ST1 SERVICE

## READING OUT THE FIRMWARE VERSION:

- 1 Connect the programming cable (with new adapter) to the PC and the Stromer
- 2 Open «StromerV120530.exe»



### IMPORTANT!

If the Stromer is connected correctly to the PC, the firmware version will be shown in the top right-hand corner of the screen and the status dot will be green.

If the Stromer is not connected correctly to the PC, the version number will not be displayed. The status dot will be red. In this case, the wrong COM port may have been selected (tab: System Configure).

The number of the firmware version is displayed in color; however, the different colors are only significant from Version 8.0 onwards:

**Blue:** Stromer is working properly.

**Red:** After re-loading the firmware with XC800\_FLOAD.exe: the settings still have to be loaded.  
Or the Stromer displayed Status Codes during operation that need to be read out. Please refer to «Reading out and saving Status Codes».

## LOADING FIRMWARE

- 1 «Reading out the firmware version» and - if the version is shown in red - «Reading out and saving Status Codes»
- 2 Close the programming plug
- 3 Connect the programming cable (with new adapter) to the PC and the Stromer
- 4 Switch off the programming switch
- 5 Switch on the programming switch
- 6 Open «XC800\_FLOAD.exe»

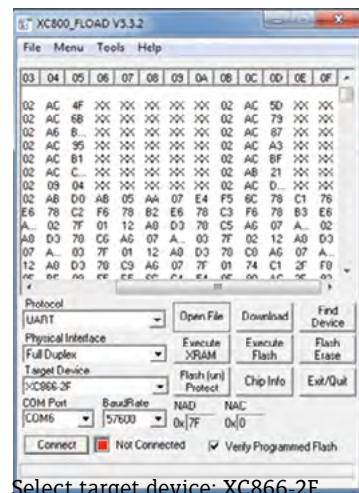

- 7 Select target device: XC866-2F
- 8 Verify Programmed Flash should be checked
- 9 Select COM port

**IMPORTANT:** A different COM port is used for each USB connection. Always use the same Stromer programming cable for same USB connection.

- 10 Carry out the following commands in the sequence shown:
  - a) «Flash Erase»
  - b) «SELECT ALL»
  - c) «ERASE NOW» the message «Flash Erase: SUCCESS» should now be displayed. If not, close the program and go back to Step 3.
  - d) «Open File»
  - e) Open «Stromer\_866\_V075.hex» in display V1: Controller firmware V5.3. When you first call this up after a new installation, you will need to navigate to the respective folder.  
For example: «c:\Program Files (x86)\STROMER v1.x Control System\STROMER V1.x Control System 20120426\»
  - f) «Download» > A window should appear with the message «Download and Verification are successful.»
  - g) «Execute Flash» > Status will be red again
  - h) «Exit/Quit»



# ST1 SERVICE

## LOADING FIRMWARE

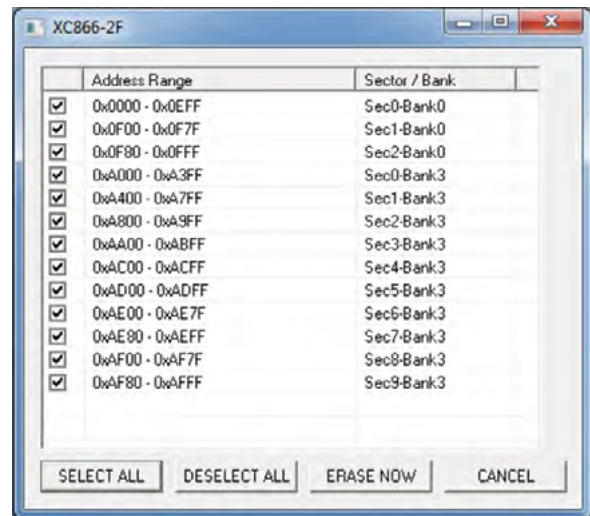
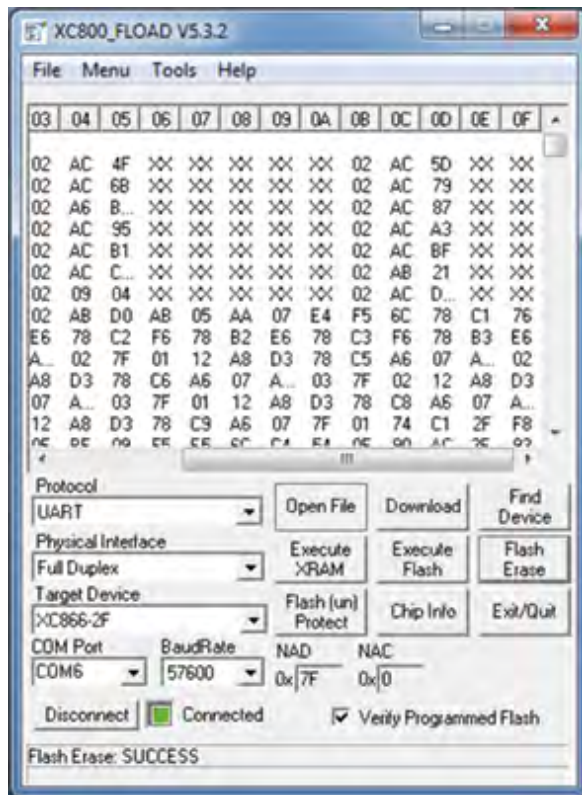

- 11 Open the programming plug (Figure 5).  
**Before using the Stromer, the settings first need to be loaded.**

# ST1 SERVICE

## LOADING THE SETTINGS

- 1 Connect the programming cable (with new adapter) to the PC and the Stromer
- 2 Open «StromerV120530.exe»

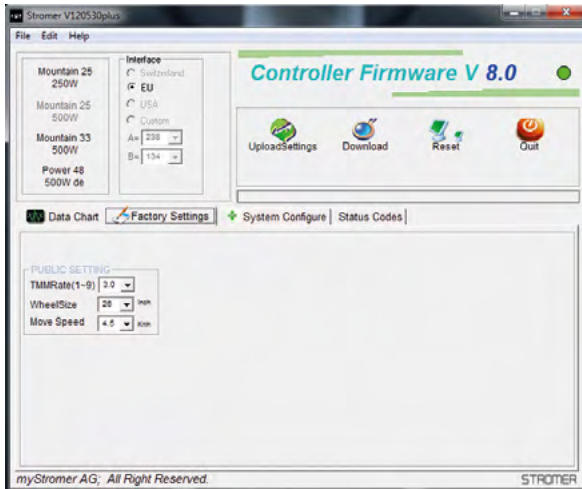
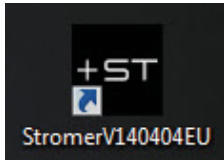

### IMPORTANT!

If the Stromer is connected correctly to the PC, the firmware version will be shown in the top right-hand corner of the screen and the status dot will be green.

If the Stromer is not connected correctly to the PC, the version number will not be displayed. The status dot will be red. In this case, the wrong COM port may have been selected (tab: System Configure).

The number of the firmware version is displayed in color; however, the different colors are only significant from Version 8.0 onwards:

**Blue:** Stromer is working properly

**Red:** After re-loading the firmware with XC800\_FLOAD.exe: the settings still have to be loaded

Or the Stromer displayed Status Codes during operation that need to be read out. Please refer to « Reading out and saving Status Codes».

### 3 «Load Settings»

- Select the command button for the right motor:

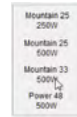

Mountain 25:	Mountain25 250W
Mountain 25:	Mountain 25 500W
Mountain 33:	Mountain 33 500W
Power 48:	Power48 500W

- The name of the motor selected will be shown in blue:



### 4 «Download»



- 5 «Upload Settings» to check that the programming is correct (optional)
- 6 «Quit»

- Select «File» > «Save Current Setting» to save customer-specific settings
- Select «File» > «Open Exist Setting» to load customer-specific settings. Please note: the settings must be suitable for the firmware version (e.g. V7.6 settings are only suitable for V7.6 Controller firmware)

# ST1 SERVICE

## WIRING ST1

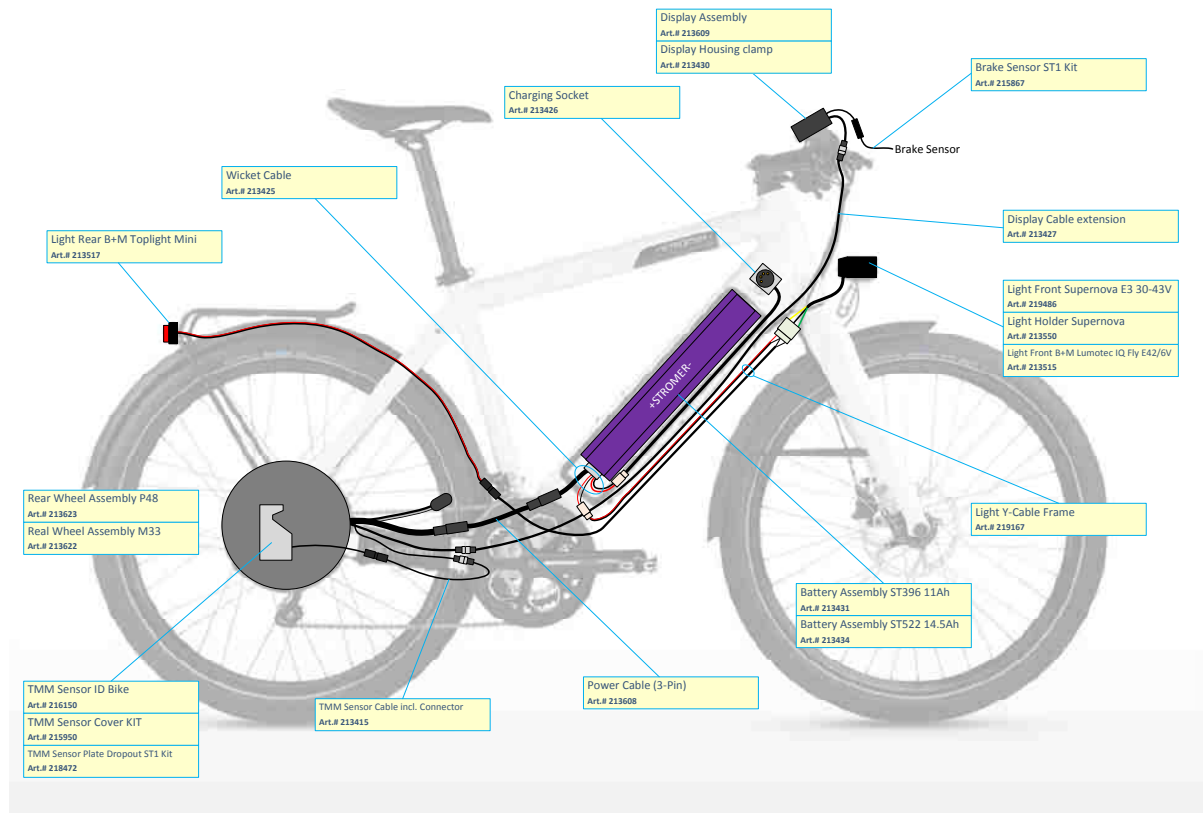

# ST1 REGULATIONS

The regulations and requirements for e-bikes are continuously being revised and may change at any time. Obtain information regarding the valid legal requirements so that you are always up to date.

For S-pedelects, special provisions apply for their limit of use. This means that e-bikes are sometimes operated like a bicycle and at other times not.

Before riding on public roads with your Stromer, inform yourself about the current legal requirements enforced in your country. This information can be found at the respective national bike or e-bike associations and online.

There you can obtain information on how your Stromer must be equipped in order to drive in traffic on public roads. These sources describe, for example, which lighting systems have to be installed and which brakes the S-pedelect must have.

The currently valid, national regulations also deal with age restrictions and specify from which age people are allowed to drive on which part of the road and whether certain driving permits are required.

The regulations for children riding on public roads are also found here. It will be made clear if a helmet is required to be worn by law.

## REPLACING PARTS

Specific components are defined in the approvals process which are allowed to be used on this vehicle.

Use original parts or replacement parts for which an expert opinion regarding the approval for your S-pedelect exists, or obtain an individual permit from the relevant licensing authority.

Parts which must only be replaced like-for-like or with approved parts are as follows:

1. Frame
2. Fork
3. Motor unit
4. Battery
5. Tires
6. Rims
7. Brake system
8. Front light
9. Rear light
10. Number plate holder
11. Side stand
12. Handlebars
13. Stem

## COMPONENTS ST2

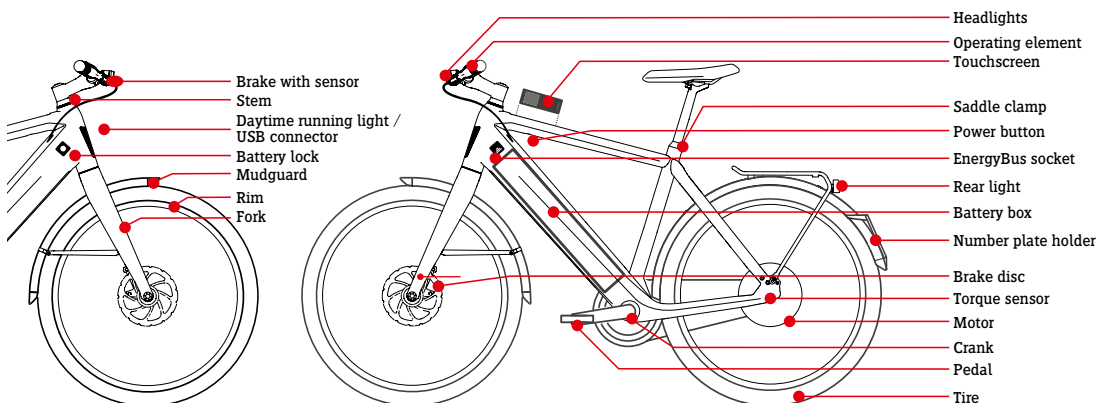

### Delivery scope



**Contents:**

- 2x Key
- Operating instructions ST2
- Battery charger

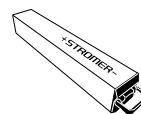





## ST2 TECH

### DESIGN

You can always recognize a Stromer at first glance. With its elegant but compelling styling, it stands out wherever it goes. The unmistakable Stromer design has undergone further refinement on the ST2; even minute details have been optimized and perfectly coordinated with an eye towards ease of servicing, comfort, operation, performance and style. The Stromer's designers have striven for maximum integration by following the principle of "less is more". All the cables are neatly out of the way inside the frame. The U-shape daytime running light is subtly integrated into the frame and makes sure other road users can better see you when you are out and about. The ST2 is a real eye-catcher that only reveals all its design secrets at second or third glance.



### RANGE

The ST2 opens up new dimensions with its operating range. Thanks to an even more efficient motor and a larger battery, you can now cover up to 100 miles before your ST2 will need fresh energy. Despite its capacity of up to 983 watt-hours, the lithium-ion battery is housed discreetly in the down tube of the frame. You can choose where and how to recharge the battery of the ST2. It can either be charged inside the frame via an external charging socket. Or the energy storage unit can simply be removed from the frame and recharged wherever you wish, using a charger. And the recuperation mode means you actually generate energy when you brake; that energy is then fed back into the battery.

	ST814	ST983 (optional)
ENERGY	814 Wh	983 Wh
VOLTAGE	48 V	48 V
WEIGHT	5 kg	5 kg



### POWER

The ST2 is driven by a veritable powerhouse in the shape of the compact, low-maintenance SYNO drive motor. The high-performance drive system enables you to accelerate even more dynamically and conquer even steep inclines with a smile on your face. And you decide for yourself how much pedaling work you want to do to help the Stromer on its way. Three support modes are available and can be called up at any time at the button ring next to the handlebar grip. It supports you up to a top speed of 28 mph – easily enough to make faster progress than a car in urban traffic.

# ST2 TECH

## CONNECTIVITY

As the world's first digitally connected e-bike, the ST2 opens up hitherto unprecedented horizons for you. You can access the main performance data and settings of your Stromer merely by glancing at your smartphone. Coming complete with GSM and GPS, the ST2 is a veritable communications expert. So the ST2 combines the many and varied benefits of the digital world with that unique experience of driving a Stromer. The following pages explain what role the cloud-based Omni platform plays in all this.



Thanks to Omni, you don't need to forego being digitally connected while out and about on your Stromer. Whether you want to fine-tune the motor or check your own performance, you can accomplish it all with consummate ease via smartphone, using Stromer's cloud-based platform – wherever you are and wherever your ST2 happens to be located. A standout feature among the extensive configuration and control options is the fully integrated anti-theft protection. The moment anyone attempts to move your locked Stromer, it blocks the motor, makes the lights flash and informs you of the incident by text message. You can also check the location of your Stromer using the built-in GPS system.

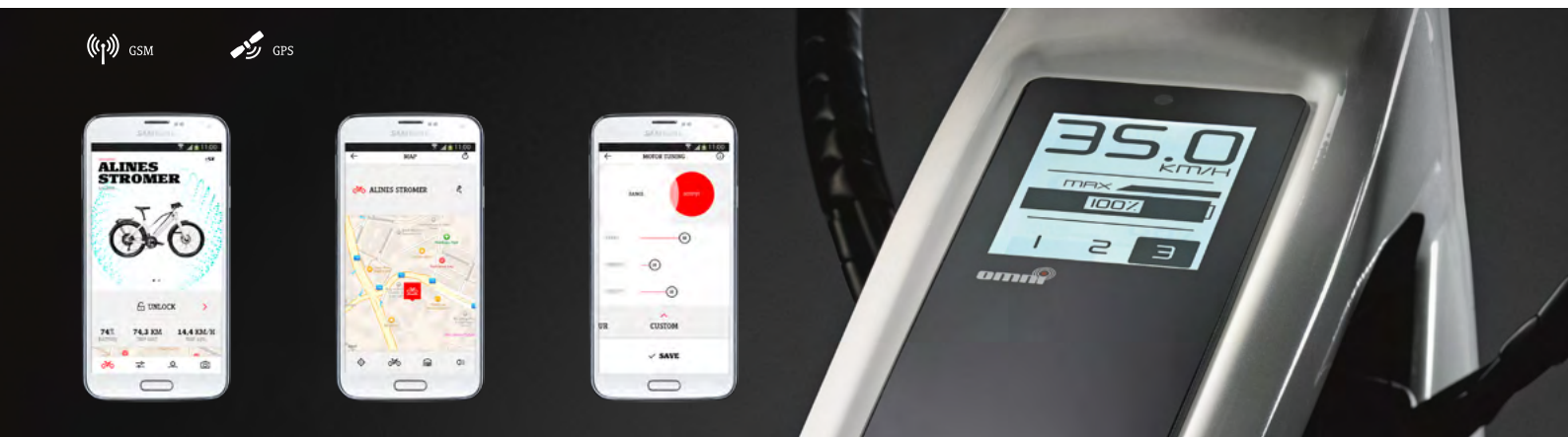
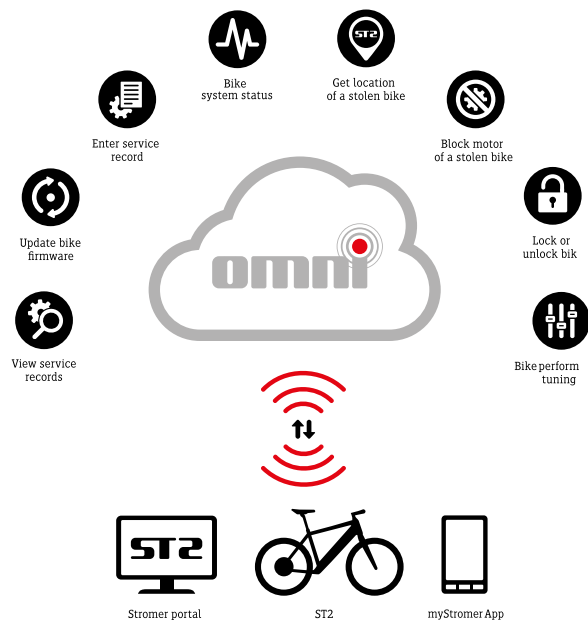

## ST2 TECH

The ST2 is available in Sport and Comfort versions. In the Sport version, you have the choice of a 22, 20 or 17-inch frame. The Comfort version with its 17-inch frame has a lower top tube for ease of climbing on and off. Both versions are equipped with 20-speed Shimano gears.

The ST2 is available in high-gloss white or matt black, and fitted with an elegant City Kit tailored specially to the requirements of Stromer riders. For example, the alloy fenders and carrier specifically match the design of the Stromer. The individually adapted Supernova headlight with a maximum light intensity of 1,600 lumens and the efficient rear light are integrated elegantly into the bike, to make sure other road users spot you.

### MOTOR

The SYNO drive motor is a brushless, direct-current motor integrated into the rear hub of the ST2. Because industrial-grade ball bearings are the only mechanical contact, the system runs incredibly quietly, hugely efficiently and requires virtually no maintenance. 500 watts of motor power at a torque of 35 Newton-meters will have you flying up even the steepest of ascents.

### BATTERY

The ST2 will get you further than you imagine on its 48 V battery with lithium-ion cells. Integrated discreetly in the down tube, the power pack has a capacity of up to 983 watt-hours, enough for a range of up to 100 miles. The battery is incredibly easy to charge, either directly in the frame or externally, using a separate charger.

### CARBON FORK

The carbon fork of the ST2 also perfectly blends driving control and driving comfort. This sophisticated material is not only extremely light, but also strong. The fork effortlessly absorbs impact and vibrations, making even the bumpiest of roads comfortable to ride along.

### TIRES

As the elements that connect the bike to the road, perfect tires are crucial to both driving safety and driving comfort. That is why Stromer commissioned the development of tires with special characteristics for the ST2. As a Stromer driver, you can look forward to exceptionally good shock absorption, outstanding grip and integrated puncture protection.

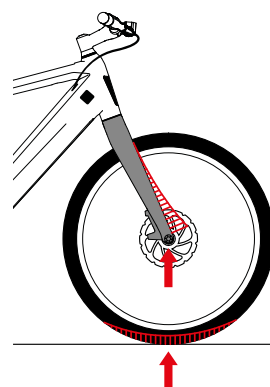

# ST2 TECH

### SADDLE

A matching custom-made saddle was developed for the ST2 that is in keeping with the bike's refined design without compromising ergonomics and comfort.

### CITY KIT

Bespoke Stromer fenders harmonize with the overall aesthetics of the bike and protect you even under the most adverse of conditions. Our Stromer Racktime carrier was reduced to the bare essentials, assumes a perfect position over the rear wheel, and is functional and robust. The impressively compact Supernova headlight that further complements the ST2 outputs a very respectable 165 lumens. The rear light is also highly efficient and ensures that you won't be overlooked.

### SPECIFICATION ST2

FORK	Stromer carbon fork
BRAKES	Magura MT2/4, 180 mm, with integrated regenerative braking sensor
DRIVETRAIN	Shimano, 20-Speed, 52X36T, CS 11-34T
HEADLIGHT	Stromer custom Supernova
REARLIGHT	Busch+Müller Toplight Mini
DAYTIME LIGHTS	Stromer front and rear integrated (available according to market specific law)
FENDERS	Stromer custom alloy
CARRIER	Stromer custom Racktime
TIRES	Stromer custom Schwalbe BigBen 26X2.15
SADDLE	Stromer custom

### GEOMETRY

	MODELL	A	B	C	D	E	F	G	H
up to 178 CM	Sport 17"	432	582	205	73,3	70,3	435	416	47
above 175 CM	Sport 20"	508	582	205	73,3	70,3	435	416	47
above 185 CM	Sport 22"	559	605	205	73,3	70,3	435	416	47
up to 178 CM	Comfort 17"	432	582	205	73,3	70,3	435	416	47

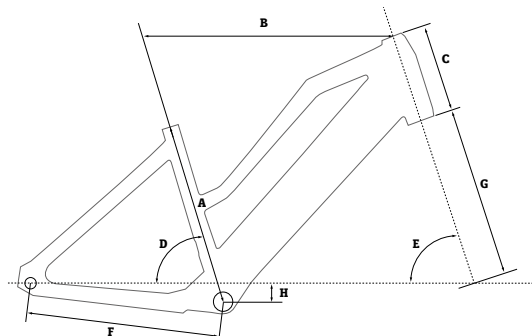
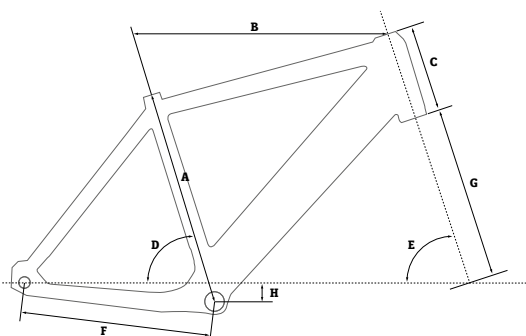

## ST2 PRODUCT OFFERINGS

# ST2 S

The ST2 S with subtle gray finish is available with a 17, 20 or 22-inch sport frame. Its equipment is worthy of a premium model: powered by the dynamic SYNO drive motor and the biggest and most powerful battery on the e-bike market, with a 983 watt-hour capacity, the ST2 S allows a distinctively sporty form of riding.

For maximum ease of gear changing in any situation, it is fitted with the electronic Shimano XTR Di2 with its eleven gears that can be selected at the push of a button.

Regardless of the time of day or weather conditions, the 1,600-lumens Supernova M99 Pro lighting integrated elegantly into the design assures you of an excellent view with day light, high beam and low beam. The special

Continental Top Contact II tires, too, combine efficiency with comfort. Despite their low weight, they reliably absorb jolts and vibration without compromising on rolling resistance.

Other advantages that benefit the efficiency and therefore range of your Stromer are the lightweight DT Swiss wheels – the key to an even more dynamic drive. And bringing the bike to a stop effectively, even from high speeds, is never a problem with the Magura MT5 brakes.

The ST2 S is the obvious athlete among Stromer e-bikes, thanks to its very high-performance equipment. You too can discover an exclusive caliber of driving comfort with a sporty slant, while feeling in control and at ease in every situation and at every speed.



<b>FRAME COLORS</b>	
<b>FORK</b>	Stromer ST2 carbon fork
<b>BRAKES</b>	Magura MT Next e / MT5
<b>GEARSHIFT</b>	Shimano XTR Di2   11-gear
<b>CRANK</b>	FSA   52T
<b>REAR COGS</b>	Shimano 11–40T
<b>HEADLIGHT</b>	Supernova M99 Pro
<b>REAR LIGHT</b>	Supernova
<b>DAYTIME RUNNING LIGHT</b>	integrated Stromer daytime running light
<b>FENDERS</b>	Stromer custom aluminum
<b>TIRES</b>	Continental Top Contact II   26x2.0
<b>SADDLE</b>	Stromer custom Sport
<b>MOTOR</b>	SYNO Drive*
SUPPORTED SPEED	up to 30 mph
OUTPUT	500 W
TORQUE	35 Nm
RANGE	40–110 miles
<b>BATTERY</b>	ST983
ENERGY	983 Wh
VOLTAGE	48 V
WEIGHT	5 kg
<b>FRAME SIZE</b>	< 178 cm = Sport 17"
	175–188 cm = Sport 20"
	> 185 cm = Sport 22"

## ST2 TECH

### RELEASE NOTES ST2 FIRMWARE

An overview of key ST2 firmware modifications is provided below. You can view the firmware versions currently installed via the menu: MENU/SYSTEM/VIA

SUI FW = touchscreen firmware

TNT FW = communication module firmware

Firmware updates are sent automatically to your ST2. To enable your ST2 to receive a firmware update, switch it on. The ST2 will need good cell network reception for at least ten minutes. On the SUI FW version 1.4.x and later versions, an indicator notifies you when there is an update ready to install. When the update is ready, activate the (OFF) switch. A dialog window appears on the ST2 touchscreen. Here you can choose whether to install the update immediately (Yes) or later (No). You can install the update immediately or postpone installation of the update up to seven times. You will then have to install it.

#### SUI FW 3.0.1

Designation: SUI FW: 3.0.1 NEW  
TNT FW: 2.0

Release date: May 27, 2016

Description:

This bug fix release is only available for the ST2 S and ST2 with ST983 battery.

- Setting time
  - Time is set on the battery and saved
  - Time can be set in a one-time process for each battery
  - No renewed setting of time needed after changing battery
- Various bug fixes for SUI FW 3.0.0 – including
  - Battery warnings – self clearing
  - Reduced power consumption in standby

#### SUI FW 3.0.0

Designation: SUI FW: 3.0.0 NEW  
TNT FW: 2.0

Release date: April 18, 2016

Description:

This update is only available for the ST2 S and ST2 with ST983 battery. M99-Pro lamp and ST983 battery are not compatible with older SUI firmware versions.

- Functions for ST2 S and ST983 battery
  - Light management for M99-Pro
  - Compatibility of ST983 battery
  - Speed display modified in accordance with wheel circumference of ST2 S

- Torque sensor calibration in Sensor menu
  - To be performed if no or irregular assistance
  - When executing unload the pedals and sit on the saddle
- Revised theft protection is to prevent user from riding off in error when bike is locked.
  - Braking effect when vehicle locked
  - Lights flash and PIN input field is displayed before the theft mode is activated

#### SUI FW 2.0.0

#### TNT FW 2.0

Designation: SUI FW: 2.0.0 NEW  
TNT FW: 2.0 NEW

Release date: December 12, 2015

Description:

#### SUI & TNT firmware

- New communication protocol between bike and myStromer app
  - Shorter transaction time
  - Enhanced connection status transparency
  - Supports myStromer App 2.0 (Borium)
- New calculation of battery charge level display
  - Fewer variations at low temperatures
  - Full charge also possible at low temperatures
- New light management system to meet EU Directive which comes into force in 2016
  - Lighting switches on automatically when vehicle starts
  - Daytime running light settings removed from menu

#### myStromer app

- Improved user experience
  - Faster transfer of data between smartphone app and bike
  - Connection status display
  - Design and user interface fully revamped
  - Badges for reaching certain destinations
- The app offers additional functions
  - Locking and unlocking using the app
  - Motor and battery temperature
  - Battery life status
  - Stromer Cam - share your Stromer images on social networks
- To benefit from the app's optimizations, the following need to be installed for all components as a minimum:
  - ST2 firmware: SUI FW = 2.0.0
  - TNT FW = 2.0
  - myStromer app version = 2.0 (Borium)

Support for older versions of the app will cease from December 12, 2015 and they will no longer be able to com-



# ST2 TECH

## RELEASE NOTES ST2 FIRMWARE

municate with the ST2. Please download and install the current myStromer app as soon as possible.

The TNT FW 2.0 and SUI FW 2.0.0 will only transmit to ST2 with TNT FW 1.1 and SUI FW 1.5.0 or later versions. For bikes with older firmware, you will first need to install TNT FW 1.1 and SUI FW 1.5.0.

### SUI FW 1.5.2

Designation: SUI FW: 1.5.2 NEW  
TNT FW: 1.1

Release date: October 26, 2015

#### Description:

SUI FW 1.5.2 is installed on new touchscreens for Production and Service. It is not installed on all bikes across-the-board.

- Support for new motor controller version
  - Supports controller with built-in CAN protection unit
- New display setup for improved contrast
  - Improved contrast calibration in Production display

### SUI FW 1.5.0

Designation: SUI FW: 1.5.0 NEW  
TNT FW: 1.1

Release date: May 19, 2015

#### Description:

- Optimization of communication when ST2 is switched on:
  - Position is updated every 10 minutes
  - Status is updated every 10 minutes
- Optimized energy management when locked
  - Reduced energy demand when locked
  - More accurate indication of the battery charge level after unlocking
  - Bike flashes only for the first 5 minutes after locking
- New error handling:
  - Smartphone recharged at the USB charging socket without generating an OMNI error
  - General stability improvements
- Optimization of the SIT
  - Shorter delay in the USB test
  - Bike remains switched on after the SIT

### SUI FW 1.4.0

Designation: SUI FW: 1.4.0 NEW  
TNT FW: 1.1

Release date: April 21, 2015

#### Description:

- Battery charge display:
  - A more accurate calculation approach for the battery charge display ensures the battery is fully charged up at the end of the charging process.
  - **IMPORTANT:** For optimum charging results, the battery should ideally be charged and stored at room temperature. The battery cannot reach its full capacity in a cold environment.
- New indicators to display mobile network reception:
  - New indicator for GSM signal strength in the riding display
    - The more bars are solid, the stronger the signal is
  - New indicator for GSM signal strength in the riding display
    - Circle with a line through it = GSM and GPRS are offline
    - G = GPRS online
    - No G = GPRS offline
    - **IMPORTANT:** Without GPRS, the ST2 cannot communicate.
  - New indicator for exchanging data packages
    - Flashing arrow pointing down = ST2 receiving data
    - Flashing arrow pointing up = ST2 sending data
  - New indicator if new firmware is available for your ST2
    - Flashing arrow in box = update being loaded
    - Arrow in box = update ready for installation. The next time you switch on/off, you will be asked whether you would like to install the firmware.
- Optimized features of touchscreen:
  - The touchscreen is switched off if no PIN is entered for more than one minute when in the locked mode.
  - Responsiveness of the touchscreen has been optimized so that commands can be input more precisely and incorrect inputs are minimized.
- Optimizing system integration test (SIT)
  - SIT button ring test new only successful if the buttons are also released again. This helps to identify Yesmmed buttons.

### SUI FW 1.3.0

Designation: SUI FW: 1.3.0 NEW  
TNT FW: 1.1

Release date: Internal release was never published



# ST2 TECH

## RELEASE NOTES ST2 FIRMWARE

### TNT FW 1.01

Designation: SUI FW: 1.2.00  
TNT FW: 1.01 NEW

Release date: Yesnuary 16, 2015

#### Description:

- Mobile communication is more stable. Has no influence on range of functions or handling

### SUI FW 1.2.00

Designation: SUI FW: 1.2.00 NEW  
TNT FW: 1.00

Release date: July 23, 2014

#### Description:

- Supports new functions of the myStromer smartphone app (from app version: Argentum/ August 2014):
  - o The remote locking and unlocking function is replaced by the "AUTOLOCK" function. With "AUTOLOCK", you can activate a timer for the automatic lock on the ST2. Via app, you can determine a period of time after which your ST2 is automatically locked. To unlock your bike again, you must enter the PIN when you switch it on.
  - o The adjustments that you can make via app under "Tuning" are now much more noticeable.
  - o New features are that you can make ST2 system settings such as time, language and units via app.
- The firmware update optimizes the charging process when you charge the battery directly in the ST2.
- Flashing in the locked mode is reduced. Only the daytime running lights now flash.
- Display of system messages is optimized.
- Other adjustments
- The firmware update has now added the following to the Service menu:
  - o New: the Sensor menu – it permits torque sensor reset and a brake sensor test.
  - o New: a menu item that displays the bike's most recent fault messages that have not yet been loaded on the portal.
  - o New: settings for the daytime running lights; system integration test (SIT); MCU parameters

### SUI FW 1.1.00

Designation: SUI FW: 1.1.00 NEW  
TNT FW: 1.00

Release date: April 9, 2014

#### Description:

- System languages: German, English, French, Dutch, Italian
- Takes account of the braking mode during the regeneration mode

- Scope for ending the regeneration mode automatically if the speed is low and the driver operates the pedals.
- The PIN input to unlock the ST2 was supplemented with the option of entering numbers.
- New move mode display
- New option for selecting time format: 12hr / 24hr
- New Service menu with daytime running lights settings and system integration test (SIT)
- New: overvoltage protection in regeneration mode

### RELEASE 1

Designation: SUI FW: 1.0.01  
TNT FW: 1.00

Release date: March 12, 2014











#### Description:

- Basic functions of ST2













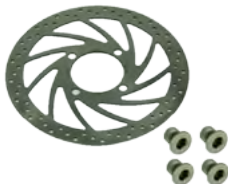

# ST2 SPARE PARTS USD

Spare Parts ST2		ST2	Shared by ST2 and ST2 S	ST2 S
29/4/2016				
USA				
<b>Mechanical drive parts</b>				
	Stromer Art. # <b>221248</b> Crankset 2x10 17" ST2 170mm crank arm length  WSP USD 135.00 MSRP USD 235.00		Stromer Art. # <b>221247</b> Crankset 2x10 20" & 22" ST2 175mm crank arm length  WSP USD 135.00 MSRP USD 235.00	
	Stromer Art. # <b>400261</b> Crankset 1x11 17 SP Kit ST2S ST2 S 170mm crank arm length  WSP USD 170.00 MSRP USD 280.00		Stromer Art. # <b>400262</b> Crankset 1x11 20 & 22 SP Kit ST2S ST2 S 175mm crank arm length  WSP USD 170.00 MSRP USD 280.00	
	Stromer Art. # <b>400260</b> Chain ring 1x11 SP Kit ST2S ST2 S  WSP USD 80.00 MSRP USD 135.00	Picture not yet available	Stromer Art. # <b>400478</b> Derailleur Washer ST2 S ST2 S 16x10x2mm  WSP USD 3.00 MSRP USD 6.00	
<b>Battery</b>				
	Stromer Art. # <b>219554</b> Battery 814Wh ST2  WSP USD 742.00 MSRP USD 1100.00		Stromer Art. # <b>221356</b> Battery handle ST2 & ST2 S  incl. Axle WSP USD 8.00 MSRP USD 16.00	
	Stromer Art. # <b>400209</b> Battery 983Wh ST2 S  WSP USD 1081.00 MSRP USD 1600.00			
<b>Brake</b>				
	Stromer Art. # <b>221332</b> Brake Magura MT4e front ST2 to be replaced by 400328 includes rotor & mounting bolts  WSP USD 170.00 MSRP USD 280.00		Stromer Art. # <b>221334</b> Brake Magura MT4e rear ST2 to be replaced by 400329 includes rotor & mounting bolts  WSP USD 180.00 MSRP USD 290.00	
Picture not yet available	Stromer Art. # <b>400328</b> Brake Assembly Front MT4 Next e ST2 includes rotor & mounting bolts  WSP USD 160.00 MSRP USD 270.00	Picture not yet available	Stromer Art. # <b>400329</b> Brake Assembly Rear MT4 Next e ST2 includes rotor & mounting bolts  WSP USD 170.00 MSRP USD 280.00	





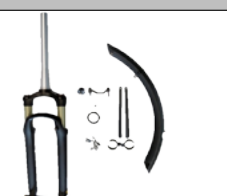





**ST2 SPARE PARTS USD**

	<p>Stromer Art. # <b>400330</b></p> <p>Brake Assembly Front MT5 Next e <b>ST2 S</b></p> <p>Plugs not compatible with ST2!</p> <p>includes rotor &amp; mounting bolts</p> <p>WSP USD 180.00 MSRP USD 310.00</p>		<p>Stromer Art. # <b>400331</b></p> <p>Brake Assembly Rear MT5 Next e <b>ST2 S</b></p> <p>Plugs not compatible with ST2!</p> <p>includes rotor &amp; mounting bolts</p> <p>WSP USD 190.00 MSRP USD 320.00</p>
	<p>Stromer Art. # <b>221367</b></p> <p>Brake rotor rear <b>ST2 &amp; ST2 S</b></p> <p>Includes rotor screws</p> <p>WSP USD 20.00 MSRP USD 40.00</p>		<p>Stromer Art. # <b>222010</b></p> <p>Rear brake rotor screw kit <b>ST2 &amp; ST2 S</b></p> <p>4 screws</p> <p>WSP USD 5.00 MSRP USD 10.00</p>
	<p>Stromer Art. # <b>215567</b></p> <p>Brake Pads Magura 7.2, pair <b>ST1 &amp; ST2</b></p> <p>WSP USD 22.00 MSRP USD 44.00</p>		<p>Stromer Art. # <b>400332</b></p> <p>Brake Pads Magura 7.4, pair <b>ST2</b></p> <p>Not homologated for ST1</p> <p>WSP USD 22.00 MSRP USD 44.00</p>
	<p>Stromer Art. # <b>400333</b></p> <p>Brake Pads Magura 9.1, pair <b>ST2 S</b></p> <p>Only fits MT5 caliper</p> <p>WSP USD 22.00 MSRP USD 44.00</p>		
<b>Fork</b>			
	<p>Stromer Art. # <b>221242</b></p> <p>Fork <b>ST2</b></p> <p>white, 283mm steerer tube</p> <p>WSP USD 340.00 MSRP USD 520.00</p>		<p>Stromer Art. # <b>221357</b></p> <p>Fork <b>ST2</b></p> <p>black, 283mm steerer tube</p> <p>WSP USD 340.00 MSRP USD 520.00</p>
	<p>Stromer Art. # <b>400327</b></p> <p>Fork grey <b>ST2 S</b></p> <p>283mm steerer tube</p> <p>WSP USD 340.00 MSRP USD 520.00</p>		
<b>Federgabel Kit / Suspension Fork Kit</b>			
	<p>Stromer Art. # <b>400031</b></p> <p>Suspension Fork SR Epixon <b>ST2 &amp; ST2 S</b></p> <p>Gloss black</p> <p>WSP USD 350.00 MSRP USD 695.00</p>		<p>Stromer Art. # <b>400032</b></p> <p>Suspension Fork SR Epixon <b>ST2 &amp; ST2 S</b></p> <p>Matte black</p> <p>WSP USD 350.00 MSRP USD 695.00</p>

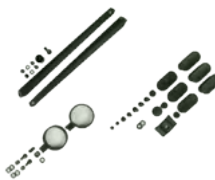

# ST2 SPARE PARTS USD

Through Axle			
	<p>Stromer Art. # <b>221243</b></p> <p>Front axle All ST1 and ST2 with carbon fork</p> <p>WSP USD 20.00 MSRP USD 40.00</p>		
Fender / Carrier			
	<p>Stromer Art. # <b>219202</b></p> <p>Fender Kit - front for rigid fork ST1 &amp; ST2 with carbon forks</p> <p>WSP USD 40.00 MSRP USD 80.00</p>		<p>Stromer Art. # <b>219201</b></p> <p>Fender Kit - front for suspension fork ST1 &amp; ST2 with SR Suntour forks</p> <p>WSP USD 50.00 MSRP USD 90.00</p>
	<p>Stromer Art. # <b>219204</b></p> <p>Fender parts - rear 17 &amp; 22 no plate ST1 &amp; ST2 No plate holder, for USA &amp; ST1 M25 assembly requires 213518</p> <p>WSP USD 45.00 MSRP USD 80.00</p>	Picture not yet available	<p>Stromer Art. # <b>400418</b></p> <p>Fender Kit rear 22" ST2 no plate ST2</p> <p>Use with 400432 (or 219205)</p> <p>WSP USD 50.00 MSRP USD 85.00</p>
Picture not yet available	<p>Stromer Art. # <b>400420</b></p> <p>Fender Kit rear ST2 S no plate ST2 S</p> <p>Use with 219205 (or 400432)</p> <p>WSP USD 60.00 MSRP USD 100.00</p>	Picture not yet available	<p>Stromer Art. # <b>400422</b></p> <p>Fender Kit rear 22" ST2 S no plate ST2 S</p> <p>Use with 219205 (or 400432)</p> <p>WSP USD 60.00 MSRP USD 100.00</p>
	<p>Stromer Art. # <b>400432</b></p> <p>Carrier Stromer ST2 ST2</p> <p>WSP USD 35.00 MSRP USD 70.00</p>		<p>Stromer Art. # <b>219206</b></p> <p>Fender - spare parts kit ST1 &amp; ST2</p> <p>WSP USD 15.00 MSRP USD 30.00</p>
	<p>Stromer Art. # <b>219205</b></p> <p>Fender stays - no rear carrier ST1</p> <p>incl plate holder, stays and bolts</p> <p>WSP USD 15.00 MSRP USD 30.00</p>		<p>Stromer Art. # <b>213500</b></p> <p>Fender end cap - no plate holder ST1 &amp; ST2</p> <p>WSP USD 3.00 MSRP USD 6.00</p>
	<p>Stromer Art. # <b>400480</b></p> <p>License Plate &amp; Taillight holder kit ST2 S ST2 S</p> <p>WSP USD TBD.00 MSRP USD TBD.00</p>		



# ST2 SPARE PARTS USD

Cable / Controller	
	<p>Stromer Art. # <b>221070</b></p> <p>Distribution board ST2</p> <p>WSP USD 50.00 MSRP USD 85.00</p>
	<p>Stromer Art. # <b>221071</b></p> <p>Controller ST2 &amp; ST2 S</p> <p>WSP USD 350.00 MSRP USD 580.00</p>
	<p>Stromer Art. # <b>221244</b></p> <p>Motor connector ST2 &amp; ST2 S</p> <p>WSP USD 40.00 MSRP USD 80.00</p>
	<p>Stromer Art. # <b>221370</b></p> <p>Motor Controller cable ST2 &amp; ST2 S</p> <p>WSP USD 20.00 MSRP USD 40.00</p>
	<p>Stromer Art. # <b>221349</b></p> <p>Brake sensor cable ST2</p> <p>WSP USD 20.00 MSRP USD 40.00</p>
	<p>Stromer Art. # <b>221348</b></p> <p>Charging socket ST2</p> <p>WSP USD 45.00 MSRP USD 80.00</p>
	<p>Stromer Art. # <b>400014</b></p> <p>CAN Protection Unit SP Kit ST2 ST2</p> <p>WSP USD 30.00 MSRP USD 60.00</p>
	<p>Stromer Art. # <b>400347</b></p> <p>Wicket cable ST2 S With 2A fuse</p> <p>WSP USD 55.00 MSRP USD 100.00</p>
	<p>Stromer Art. # <b>400348</b></p> <p>Button Ring Connecting Cable ST2 S Plug is color-coded yellow</p> <p>WSP USD 8.00 MSRP USD 16.00</p>
	<p>Stromer Art. # <b>400349</b></p> <p>Brake Connecting Cable ST2 S Plug is color-coded red</p> <p>WSP USD 8.00 MSRP USD 16.00</p>
	<p>Stromer Art. # <b>400350</b></p> <p>Main Light Front Connecting Cable ST2 S Plug is color-coded blue</p> <p>WSP USD 8.00 MSRP USD 16.00</p>
Picture not yet available	
	<p>Stromer Art. # <b>400470</b></p> <p>Cable Inlet ST2 S ST2 S</p> <p>WSP USD 5.00 MSRP USD 10.00</p>
	<p>Stromer Art. # <b>400430</b></p> <p>Distribution Board ST2 S ST2 S</p> <p>WSP USD 65.00 MSRP USD 110.00</p>
	<p>Stromer Art. # <b>400471</b></p> <p>Tube ST2S ST2 S</p> <p>WSP USD 5.00 MSRP USD 10.00</p>



# ST2 SPARE PARTS USD

	Stromer Art. #	<b>400472</b>
	Stem Cable Channel ST2 S	<b>ST2 S</b>
	Includes fixing screw (not pictured)	
	WSP	USD 5.00
MSRP	USD 10.00	

## Charger

	Stromer Art. #	<b>221342</b>
	Charger Premium US	<b>ST2 &amp; ST2 S</b>
	only in US	
	WSP	USD 198.00
MSRP	USD 325.00	

## Light

	Stromer Art. #	<b>221072</b>
	Daytime light	<b>ST2 &amp; ST2 S</b>
	WSP	USD 30.00
	MSRP	USD 60.00

	Stromer Art. #	<b>221252</b>
	Supernova head light adapter	<b>ST2</b>
	WSP	USD 3.00
	MSRP	USD 6.00

	Stromer Art. #	<b>221253</b>
	Supernova head light	<b>ST2</b>
	w/o adapter	
	WSP	USD 150.00
MSRP	USD 240.00	

	Stromer Art. #	<b>213517</b>
	Light rear B+M Toplight Mini	<b>ST2</b>
	incl. Cable & plug	
	WSP	USD 20.00
MSRP	USD 40.00	

	Stromer Art. #	<b>400289</b>
	Light rear Supernova M99 Taillight 6V	<b>ST2 S</b>
	WSP	USD 50.00
	MSRP	USD 90.00

	Stromer Art. #	<b>400290</b>
	Light front Supernova M99 Pro	<b>ST2 S</b>
	WSP	USD 285.00
	MSRP	USD 440.00

## Cockpit

	Stromer Art. #	<b>221074</b>
	User interface	<b>ST2 &amp; ST2 S</b>
	WSP	USD 135.00
	MSRP	USD 230.00















	Stromer Art. #	<b>219376</b>
	Bell Nuvo NH-B45AP black	<b>All</b>
	WSP	USD 3.00
	MSRP	USD 6.00

	Stromer Art. #	<b>221076</b>
	Button ring	<b>ST2</b>
	With low beam button	
	WSP	USD 20.00
MSRP	USD 40.00	













	Stromer Art. #	<b>400326</b>
	Button ring	<b>ST2 S</b>
	With high beam button	
	WSP	USD 45.00
MSRP	USD 80.00	



# ST2 SPARE PARTS USD













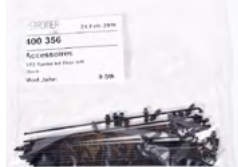

	<p>Stromer Art. # <b>221352</b></p> <p>Saddle Sport <b>ST1 S &amp; ST2 Sport</b></p> <p>WSP USD 25.00 MSRP USD 50.00</p>		<p>Stromer Art. # <b>400249</b></p> <p>Saddle Comfort <b>ST1, ST1 T &amp; ST2 Comfort</b></p> <p>WSP USD 25.00 MSRP USD 50.00</p>
	<p>Stromer Art. # <b>400334</b></p> <p>Handlebar flat <b>All ST2 &amp; ST1 S</b></p> <p>WSP USD 20.00 MSRP USD 40.00</p>		<p>Stromer Art. # <b>400259</b></p> <p>Handlebar 20mm rise <b>Optional for all ST1 &amp; ST2</b> 20 degree backsweep</p> <p>WSP USD 20.00 MSRP USD 40.00</p>
	<p>Stromer Art. # <b>213612</b></p> <p>Seat Post 17", JD-SP61, 350mm <b>All V1, ST1 &amp; ST2</b></p> <p>WSP USD 23.00 MSRP USD 46.00</p>		<p>Stromer Art. # <b>213613</b></p> <p>Seat Post 20", JD-SP61, 400mm <b>All V1, ST1 &amp; ST2</b></p> <p>WSP USD 23.00 MSRP USD 46.00</p>
	<p>Stromer Art. # <b>400252</b></p> <p>Seat Post 17", JD-SP100, 350mm <b>ST1 T, ST1 S, ST2 &amp; ST2 S</b></p> <p>WSP USD 23.00 MSRP USD 46.00</p>		<p>Stromer Art. # <b>400253</b></p> <p>Seat Post 20" &amp; 22", JD-SP100, 400mm <b>ST1 T, ST1 S, ST2 &amp; ST2 S</b></p> <p>WSP USD 23.00 MSRP USD 46.00</p>
	<p>Stromer Art. # <b>400258</b></p> <p>Grips Ergon GS1-L Black SP Kit <b>ST1 S, ST2 &amp; ST2 S</b></p> <p>WSP USD 20.00 MSRP USD 40.00</p>		<p>Stromer Art. # <b>400346</b></p> <p>Saddle fzi:k Aliante R5 grey/red <b>ST2 S</b></p> <p>WSP USD 70.00 MSRP USD 120.00</p>
	<p>Stromer Art. # <b>221254</b></p> <p>Stem 90mm ST2 <b>ST1 LE, ST1 T, ST1 S &amp; ST2</b> standard on 17"</p> <p>WSP USD 32.00 MSRP USD 64.00</p>		<p>Stromer Art. # <b>221255</b></p> <p>Stem 105mm ST2 <b>ST1 LE, ST1 T, ST1 S &amp; ST2</b> standard on 20 &amp; 22"</p> <p>WSP USD 32.00 MSRP USD 64.00</p>
	<p>Stromer Art. # <b>221256</b></p> <p>Stem 120mm ST2 <b>Optional for all ST2, ST1 T &amp; ST1 S</b></p> <p>WSP USD 32.00 MSRP USD 64.00</p>		<p>Stromer Art. # <b>400475</b></p> <p>Stem 90mm ST2 S, incl. rubber plug <b>ST2 S</b> standard on 17"</p> <p>WSP USD 35.00 MSRP USD 70.00</p>

# ST2 SPARE PARTS USD

	<p>Stromer Art. # <b>400476</b></p> <p>Stem 105mm ST2 S, incl. rubber plug ST2 S standard on 20 &amp; 22"</p> <p>WSP USD 35.00 MSRP USD 70.00</p>		<p>Stromer Art. # <b>400477</b></p> <p>Stem 120mm ST2 S, incl. rubber plug ST2 S</p> <p>WSP USD 35.00 MSRP USD 70.00</p>
	<p>Stromer Art. # <b>222233</b></p> <p>Dropper Seat Post, JD-YSP01, 400mm Optional for all ST1 &amp; ST2</p> <p>WSP USD 105.00 MSRP USD 175.00</p>		
<b>Wheel</b>			
	<p>Stromer Art. # <b>213467</b></p> <p>Alex Rims FR30 rim front ST1, ST1 T, ST1 S &amp; ST2</p> <p>WSP USD 25.00 MSRP USD 50.00</p>		<p>Stromer Art. # <b>213471</b></p> <p>Alex Rims FR30 rim rear ST1, ST1 T, ST1 S &amp; ST2</p> <p>With asymmetrical hole drilling</p> <p>WSP USD 30.00 MSRP USD 60.00</p>
	<p>Stromer Art. # <b>400427</b></p> <p>Rim DT Swiss 545D 36 hole for disc black ST2 Same rim for front or rear wheel</p> <p>WSP USD 30.00 MSRP USD 60.00</p>		<p>Stromer Art. # <b>400428</b></p> <p>Hub Front Formula DC71 Gloss Black ST1, ST1 LE, ST1 T, ST1 S &amp; ST2 36 hole</p> <p>WSP USD 35.00 MSRP USD 70.00</p>
	<p>Stromer Art. # <b>400429</b></p> <p>Hub Bearings DT Swiss, 18x30x7mm, pair All ST1 &amp; ST2 Original for ST2 S front hub Upgrade for Formula DC71 front hubs</p> <p>WSP USD 28.00 MSRP USD 56.00</p>		<p>Stromer Art. # <b>221353</b></p> <p>Freewheel body Formula ST2 &amp; ST2 S</p> <p>incl. Spacer</p> <p>WSP USD 28.00 MSRP USD 56.00</p>
	<p>Stromer Art. # <b>221336</b></p> <p>Rear wheel assembly syno drive ST2 With silver spokes and Alex FR30 rim</p> <p>WSP USD 1020.00 MSRP USD 1500.00</p>	<p>Picture not yet available</p>	<p>Stromer Art. # <b>400255</b></p> <p>Rear Wheel DT Swiss ST2 S</p> <p>WSP USD 1220.00 MSRP USD 1800.00</p>
	<p>Stromer Art. # <b>400256</b></p> <p>Front Wheel DT Swiss ST2 S</p> <p>WSP USD 250.00 MSRP USD 400.00</p>		<p>Stromer Art. # <b>213619</b></p> <p>Tire Schwalbe BigBen Stromer ST2</p> <p>WSP USD 25.00 MSRP USD 50.00</p>















**ST2 SPARE PARTS USD**

	<p>Stromer Art. # <b>400423</b></p> <p>Spoke Kit ST1 &amp; ST2 Front Left Silver <b>ST1, ST1 LE &amp; ST2</b> 20 spokes &amp; nipples</p> <p>use with Alex FR30 rim</p> <p>WSP USD 18.00 MSRP USD 36.00</p>		<p>Stromer Art. # <b>400424</b></p> <p>Spoke Kit ST1 &amp; ST2 Front Right Silver <b>ST1, ST1 LE &amp; ST2</b> 20 spokes &amp; nipples</p> <p>use with Alex FR30 rim</p> <p>WSP USD 18.00 MSRP USD 36.00</p>
	<p>Stromer Art. # <b>400352</b></p> <p>Spoke Kit ST2 Rear Left Silver <b>ST2</b> 20 spokes &amp; nipples</p> <p>use with Alex FR30 rim</p> <p>WSP USD 18.00 MSRP USD 36.00</p>		<p>Stromer Art. # <b>400353</b></p> <p>Spoke Kit ST2 Rear Right Silver <b>ST2</b> 20 spokes &amp; nipples</p> <p>use with Alex FR30 rim</p> <p>WSP USD 18.00 MSRP USD 36.00</p>
	<p>Stromer Art. # <b>400354</b></p> <p>Spoke Kit ST2 Front Left Black <b>ST2</b> 20 spokes &amp; nipples</p> <p>use with DT Swiss 545D rim</p> <p>WSP USD 24.00 MSRP USD 48.00</p>		<p>Stromer Art. # <b>400355</b></p> <p>Spoke Kit ST2 Front Right Black <b>ST2</b> 20 spokes &amp; nipples</p> <p>use with DT Swiss 545D rim</p> <p>WSP USD 24.00 MSRP USD 48.00</p>
	<p>Stromer Art. # <b>400356</b></p> <p>Spoke Kit ST2 Rear Left Black <b>ST2</b> 20 spokes &amp; nipples</p> <p>use with DT Swiss 545D rim</p> <p>WSP USD 20.00 MSRP USD 40.00</p>		<p>Stromer Art. # <b>400357</b></p> <p>Spoke Kit ST2 Rear Right Black <b>ST2</b> 20 spokes &amp; nipples</p> <p>use with DT Swiss 545D rim</p> <p>WSP USD 20.00 MSRP USD 40.00</p>
	<p>Stromer Art. # <b>400358</b></p> <p>Spoke Kit ST2 S Front Left Black <b>ST2 S</b> 20 spokes, nipples &amp; PHR rings</p> <p>use with DT Swiss EX471 rim</p> <p>WSP USD 24.00 MSRP USD 48.00</p>		<p>Stromer Art. # <b>400359</b></p> <p>Spoke Kit ST2 S Front Right Black <b>ST2 S</b> 20 spokes, nipples &amp; PHR rings</p> <p>use with DT Swiss EX471 rim</p> <p>WSP USD 24.00 MSRP USD 48.00</p>
	<p>Stromer Art. # <b>400360</b></p> <p>Spoke Kit ST2 S Rear Left Black <b>ST2 S</b> 20 spokes, nipples &amp; PHR rings</p> <p>use with DT Swiss EX471 rim</p> <p>WSP USD 20.00 MSRP USD 40.00</p>		<p>Stromer Art. # <b>400361</b></p> <p>Spoke Kit ST2 S Rear Right Black <b>ST2 S</b> 20 spokes, nipples &amp; PHR rings</p> <p>use with DT Swiss EX471 rim</p> <p>WSP USD 20.00 MSRP USD 40.00</p>
	<p>Stromer Art. # <b>400310</b></p> <p>Rim Tape Herrmans HPP 559x24 <b>ST2</b></p> <p>use with DT Swiss 545D rim</p> <p>WSP USD 3.00 MSRP USD 6.00</p>		<p>Stromer Art. # <b>400311</b></p> <p>Rim Tape Herrmans HPP 559x26 <b>ST2, ST1, ST1 LE, ST1 S, ST1 T</b></p> <p>use with Alex FR30 rim</p> <p>WSP USD 3.00 MSRP USD 6.00</p>

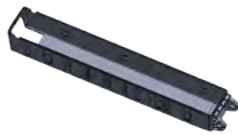
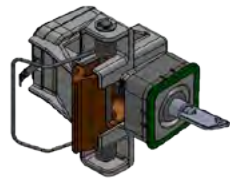













# ST2 SPARE PARTS USD

Torque Sensor TMM			
	<p><b>Stromer Art. # 221050</b></p> <p>TMM Sensor Plate ST2 &amp; ST2 S</p> <p>incl. Sensor</p> <p>WSP USD 95.00 MSRP USD 160.00</p>		
Frame			
	<p><b>Stromer Art. # 221063</b></p> <p>Cable inlets ST2</p> <p>left and right clip</p> <p>WSP USD 5.00 MSRP USD 10.00</p>		<p><b>Stromer Art. # 221246</b></p> <p>Heatsink cover ST2 &amp; ST2 S</p> <p>WSP USD 20.00 MSRP USD 40.00</p>
	<p><b>Stromer Art. # 221237</b></p> <p>Torque plate ST2 &amp; ST2 S non drive side</p> <p>WSP USD 20.00 MSRP USD 40.00</p>		<p><b>Stromer Art. # 221338</b></p> <p>Cable channel ST2 &amp; ST2 S</p> <p>WSP USD 20.00 MSRP USD 40.00</p>
	<p><b>Stromer Art. # 221240</b></p> <p>Front derailleur cable stop ST2</p> <p>WSP USD 3.00 MSRP USD 6.00</p>		<p><b>Stromer Art. # 221241</b></p> <p>Kickstand cover ST2 &amp; ST2 S</p> <p>WSP USD 3.00 MSRP USD 6.00</p>
	<p><b>Stromer Art. # 221051</b></p> <p>Frontbase tube ST2 &amp; ST2 S</p> <p>WSP USD 3.00 MSRP USD 6.00</p>		<p><b>Stromer Art. # 222310</b></p> <p>Battery box SP Kit ST2 ST2 &amp; ST2 S</p> <p>WSP USD 30.00 MSRP USD 60.00</p>
	<p><b>Stromer Art. # 222309</b></p> <p>Frontbase SP Kit ST2 ST2 &amp; ST2 S</p> <p>WSP USD 65.00 MSRP USD 110.00</p>		<p><b>Stromer Art. # 221054</b></p> <p>Charging socket cover ST2 &amp; ST2 S</p> <p>WSP USD 3.00 MSRP USD 6.00</p>
	<p><b>Stromer Art. # 221380</b></p> <p>Seatpost adapter ST2 &amp; ST2 S</p> <p>WSP USD 10.00 MSRP USD 20.00</p>		<p><b>Stromer Art. # 400254</b></p> <p>Seat Post Clamp ST2 &amp; ST2 S replaces previous 221249</p> <p>incl. M6 Nut &amp; Pivoting Bolt</p> <p>WSP USD 10.00 MSRP USD 20.00</p>



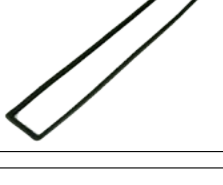







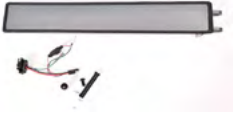





**ST2 SPARE PARTS USD**

	<p>Stromer Art. # <b>221346</b></p> <p>Headset  <b>ST1 LE, ST1 T, ST1 S, ST2 &amp; ST2 S</b>            now also includes 400257</p> <p>no crown race for SR fork</p> <p>WSP USD 25.00            MSRP USD 50.00</p>		<p>Stromer Art. # <b>221339</b></p> <p>Topcap and compressor  <b>ST1 LE, ST1 T, ST1 S, ST2 &amp; ST2 S</b></p> <p>WSP USD 8.00            MSRP USD 16.00</p>
	<p>Stromer Art. # <b>400074</b></p> <p>Headset Spacer, 10mm  <b>ST1 LE, ST1 T, ST1 S, ST2 &amp; ST2 S</b></p> <p>WSP USD 1.00            MSRP USD 2.00</p>		<p>Stromer Art. # <b>400257</b></p> <p>Headset Top Cover with Bolt  <b>ST2 &amp; ST2 S</b></p> <p>WSP USD 10.00            MSRP USD 20.00</p>
	<p>Stromer Art. # <b>219236</b></p> <p>Headset Crown Race VP J304AC  <b>All ST2, All ST1</b>            For SR Suntour suspension</p> <p>fits 219253 and 221346</p> <p>WSP USD 5.00            MSRP USD 10.00</p>		<p>Stromer Art. # <b>221337</b></p> <p>Brace front derailleur  <b>ST2</b></p> <p>WSP USD 8.00            MSRP USD 16.00</p>
	<p>Stromer Art. # <b>221245</b></p> <p>Rear axle  <b>ST2 &amp; ST2 S</b></p> <p>WSP USD 20.00            MSRP USD 40.00</p>		<p>Stromer Art. # <b>216210</b></p> <p>Frame plug bolt fender  <b>ST2 &amp; ST2 S</b></p> <p>WSP USD 3.00            MSRP USD 6.00</p>
	<p>Stromer Art. # <b>221345</b></p> <p>Axle nut cover  <b>ST2 &amp; ST2 S</b></p> <p>WSP USD 5.00            MSRP USD 10.00</p>		<p>Stromer Art. # <b>221351</b></p> <p>Cable guide motor  <b>ST2 &amp; ST2 S</b></p> <p>WSP USD 3.00            MSRP USD 6.00</p>
	<p>Stromer Art. # <b>400481</b></p> <p>Kickstand no return spring ST2  <b>ST2 &amp; ST2 S</b>            CH &amp; US Markets</p> <p>incl. Bolt &amp; Washer</p> <p>WSP USD 40.00            MSRP USD 70.00</p>		<p>Stromer Art. # <b>221239</b></p> <p>Wicket seal  <b>ST2 &amp; ST2 S</b></p> <p>WSP USD 8.00            MSRP USD 16.00</p>
	<p>Stromer Art. # <b>222312</b></p> <p>Wicket black SP Kit ST2  <b>ST2</b></p> <p>WSP USD 125.00            MSRP USD 210.00</p>		<p>Stromer Art. # <b>222311</b></p> <p>Wicket white SP Kit ST2  <b>ST2</b></p> <p>WSP USD 125.00            MSRP USD 210.00</p>



# ST2 SPARE PARTS USD

	<p>Stromer Art. # <b>400345</b></p> <p>Wicket grey <b>ST2 S</b></p> <p>includes wicket cable 400347</p> <p>WSP USD 120.00 MSRP USD 200.00</p>		<p>Stromer Art. # <b>221343</b></p> <p>Touch up paint <b>ST2</b> White (W700I)</p> <p>WSP USD 5.00 MSRP USD 10.00</p>
	<p>Stromer Art. # <b>221344</b></p> <p>Touch up paint <b>ST1 &amp; ST2</b> Black (K720T)</p> <p>WSP USD 5.00 MSRP USD 10.00</p>		<p>Stromer Art. # <b>400318</b></p> <p>Touch-up paint <b>ST2 S</b> Grey (A909W)</p> <p>WSP USD 5.00 MSRP USD 10.00</p>
<b>Accessories</b>			
	<p>Stromer Art. # <b>221078</b></p> <p>SUI Nut tool <b>ST2 &amp; ST2 S</b></p> <p>WSP USD 50.00 MSRP USD 90.00</p>		<p>Stromer Art. # <b>221081</b></p> <p>Manual Deutsch ST2 <b>ST2 &amp; ST2 S</b></p> <p>WSP USD 3.00 MSRP USD 6.00</p>
	<p>Stromer Art. # <b>221082</b></p> <p>Manual Francais ST2 <b>ST2 &amp; ST2 S</b></p> <p>WSP USD 3.00 MSRP USD 6.00</p>		<p>Stromer Art. # <b>221083</b></p> <p>Manual Italiano ST2 <b>ST2 &amp; ST2 S</b></p> <p>WSP USD 3.00 MSRP USD 6.00</p>
	<p>Stromer Art. # <b>221084</b></p> <p>Manual Nederlands ST2 <b>ST2 &amp; ST2 S</b></p> <p>WSP USD 3.00 MSRP USD 6.00</p>		<p>Stromer Art. # <b>221085</b></p> <p>Manual English ST2 <b>ST2 &amp; ST2 S</b></p> <p>WSP USD 3.00 MSRP USD 6.00</p>
	<p>Stromer Art. # <b>215589</b></p> <p>BMC Group Operating Manual DE/FR <b>All ST1 and ST2</b></p> <p>WSP USD 3.00 MSRP USD 6.00</p>		<p>Stromer Art. # <b>215590</b></p> <p>BMC Group Operating Manual EN/SP <b>All ST1 and ST2</b></p> <p>WSP USD 3.00 MSRP USD 6.00</p>
	<p>Stromer Art. # <b>215591</b></p> <p>BMC Group Operating Manual IT/NL <b>All ST1 and ST2</b></p> <p>WSP USD 3.00 MSRP USD 6.00</p>		<p>Stromer Art. # <b>221359</b></p> <p>Trailer plate Kit Stromer ST2 <b>ST2 &amp; ST2 S</b> Not legal for use in the EU</p> <p>WSP EUR 90.00 MSRP USD 50.00</p>



## ST2 SPARE PARTS USD

	Stromer Art. # <b>400002</b>
	Sticker Stromer Demo Bike Black All Each
WSP	USD 3.00
MSRP	USD 6.00

Picture not yet available	Stromer Art. # <b>400473</b>
	Cable Support Tool ST2 S ST2 S
WSP	USD TBD.00
MSRP	USD TBD.00

Picture not yet available	Stromer Art. # <b>400474</b>
	Cable Hook Tool ST2 S ST2 S
WSP	USD TBD.00
MSRP	USD TBD.00



# DIAGNOSIS

## NO CONNECTION TO OMNI

In this flowchart as few defects as possible will be shown, because it is based on a very dynamic software landscape which can change quickly. In case of doubt, do not hesitate to contact the Stromer customer service.

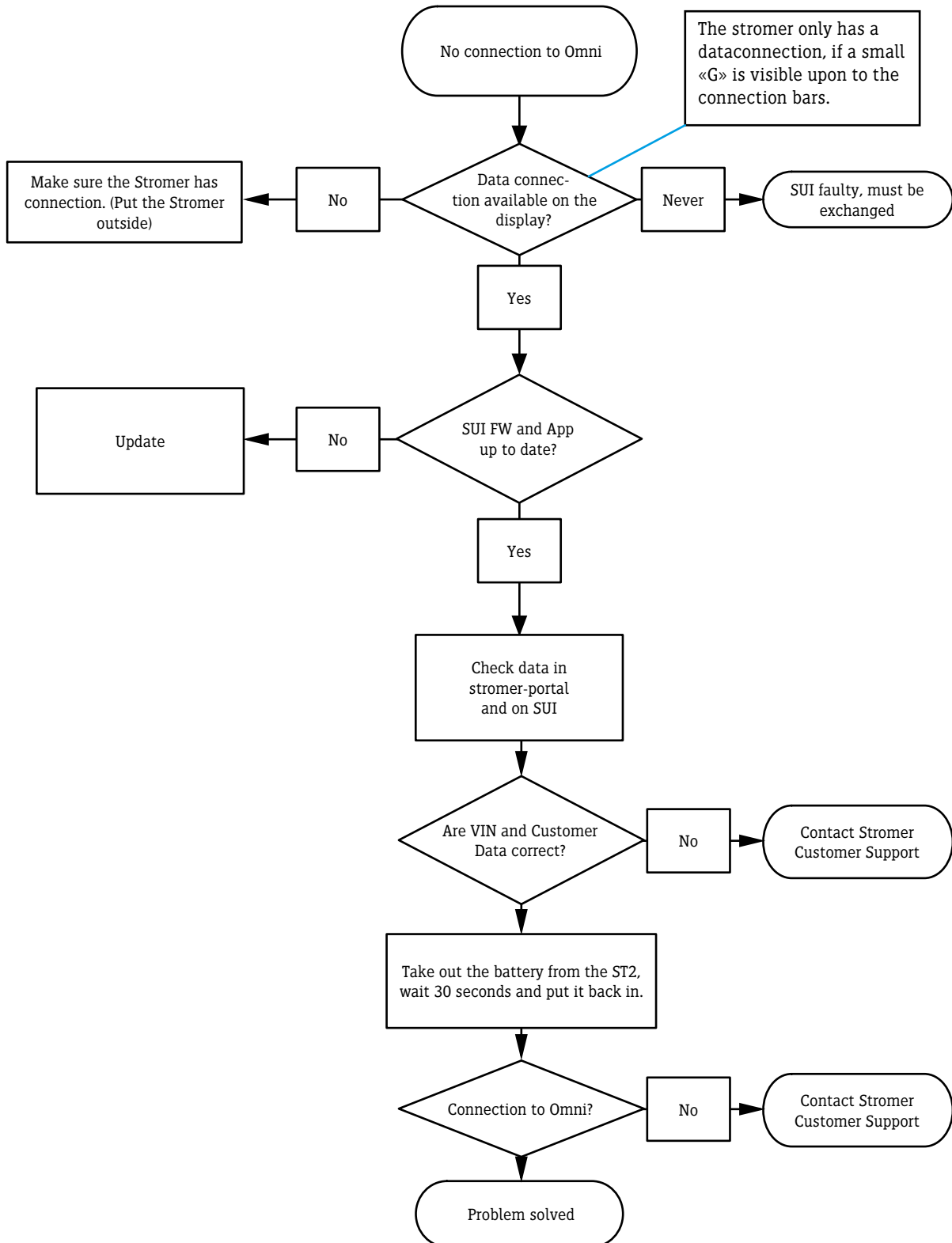

# DIAGNOSIS

## NO ERROR BUT NO ASSISTANCE

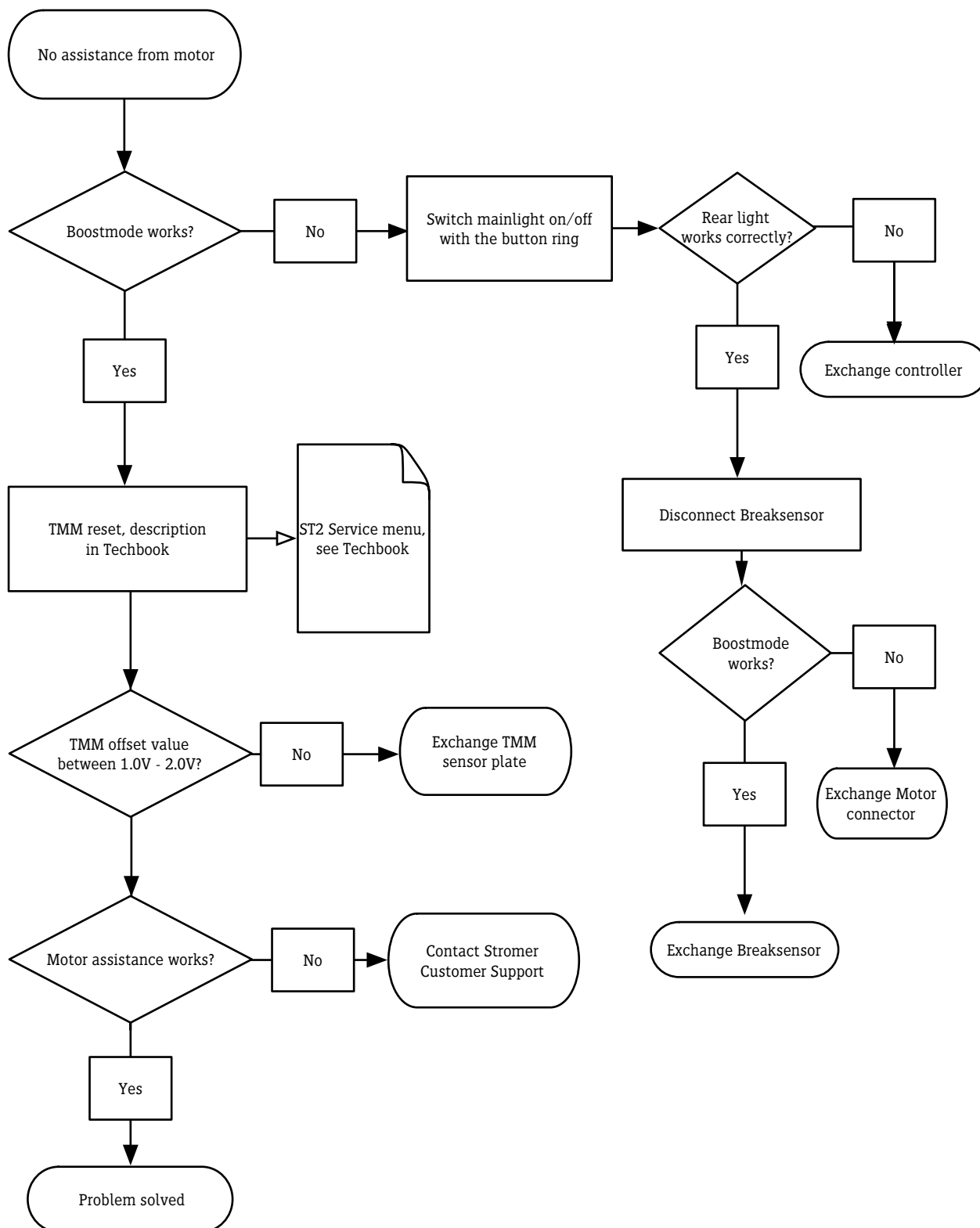

# DIAGNOSIS

## BATTERY INDICATOR SHOWS CONSTANTLY 0%

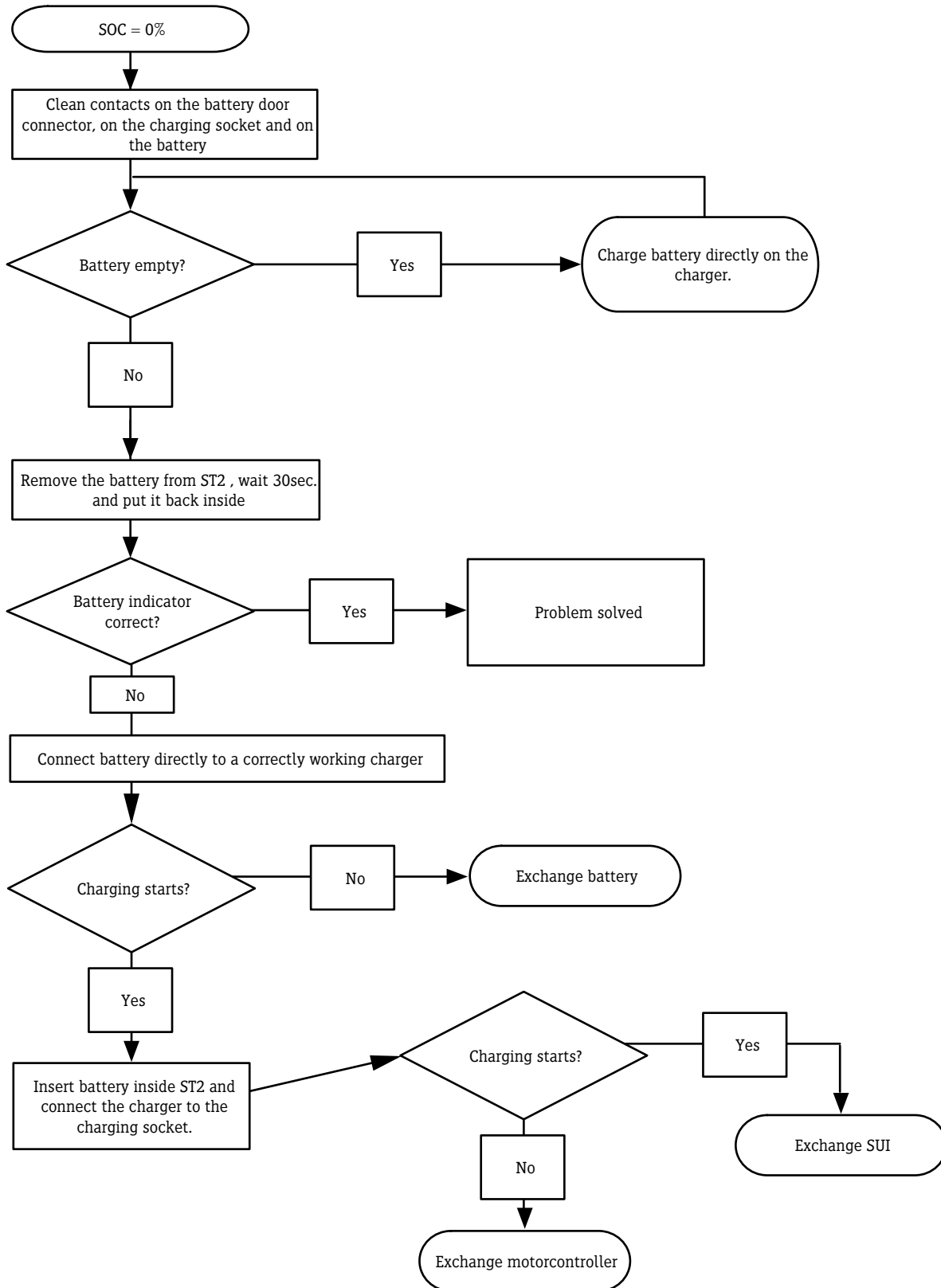

# DIAGNOSIS

## CHARGING DOESN'T START

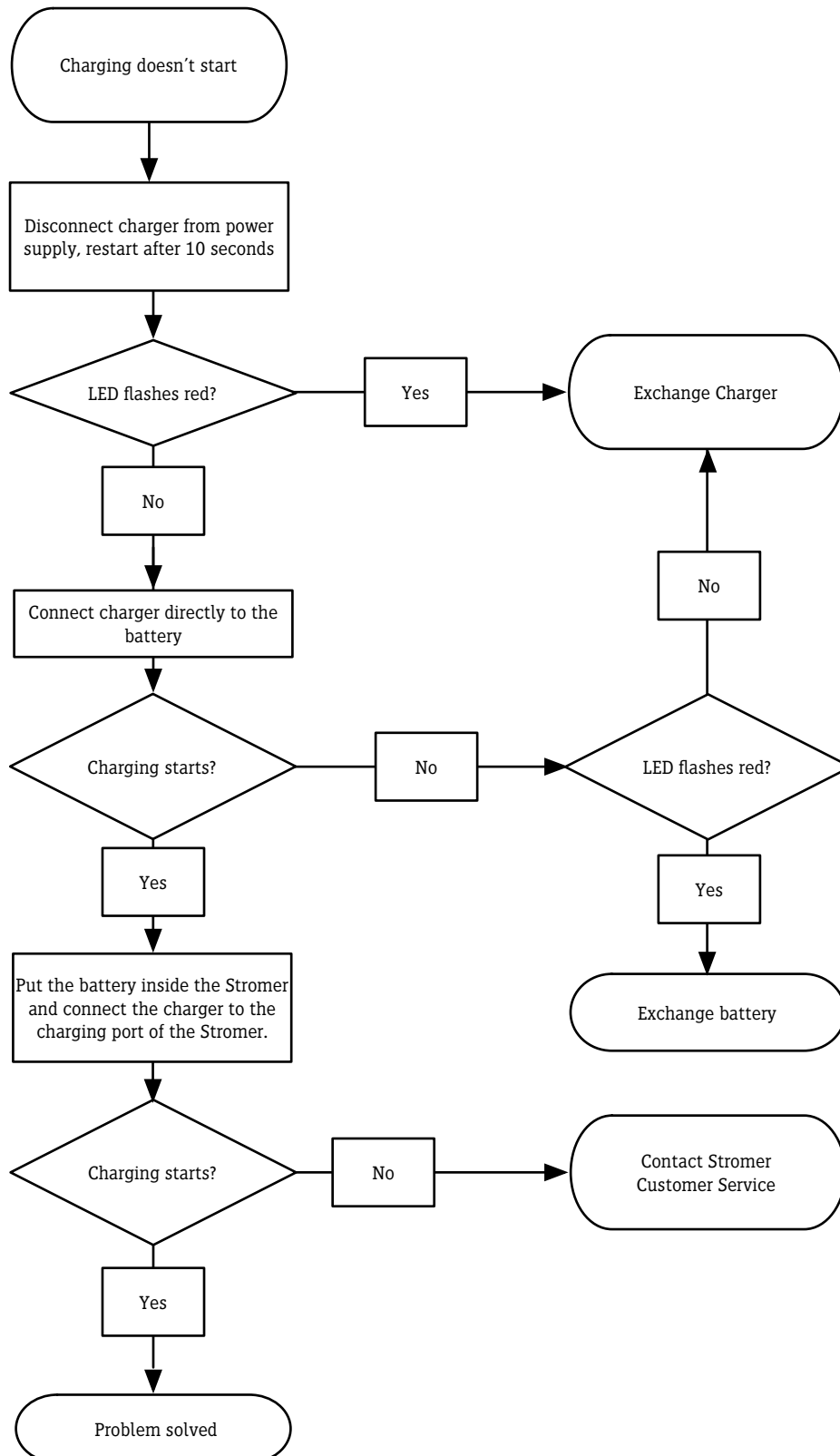

# DIAGNOSIS

## SYSTEM DOESN'T START

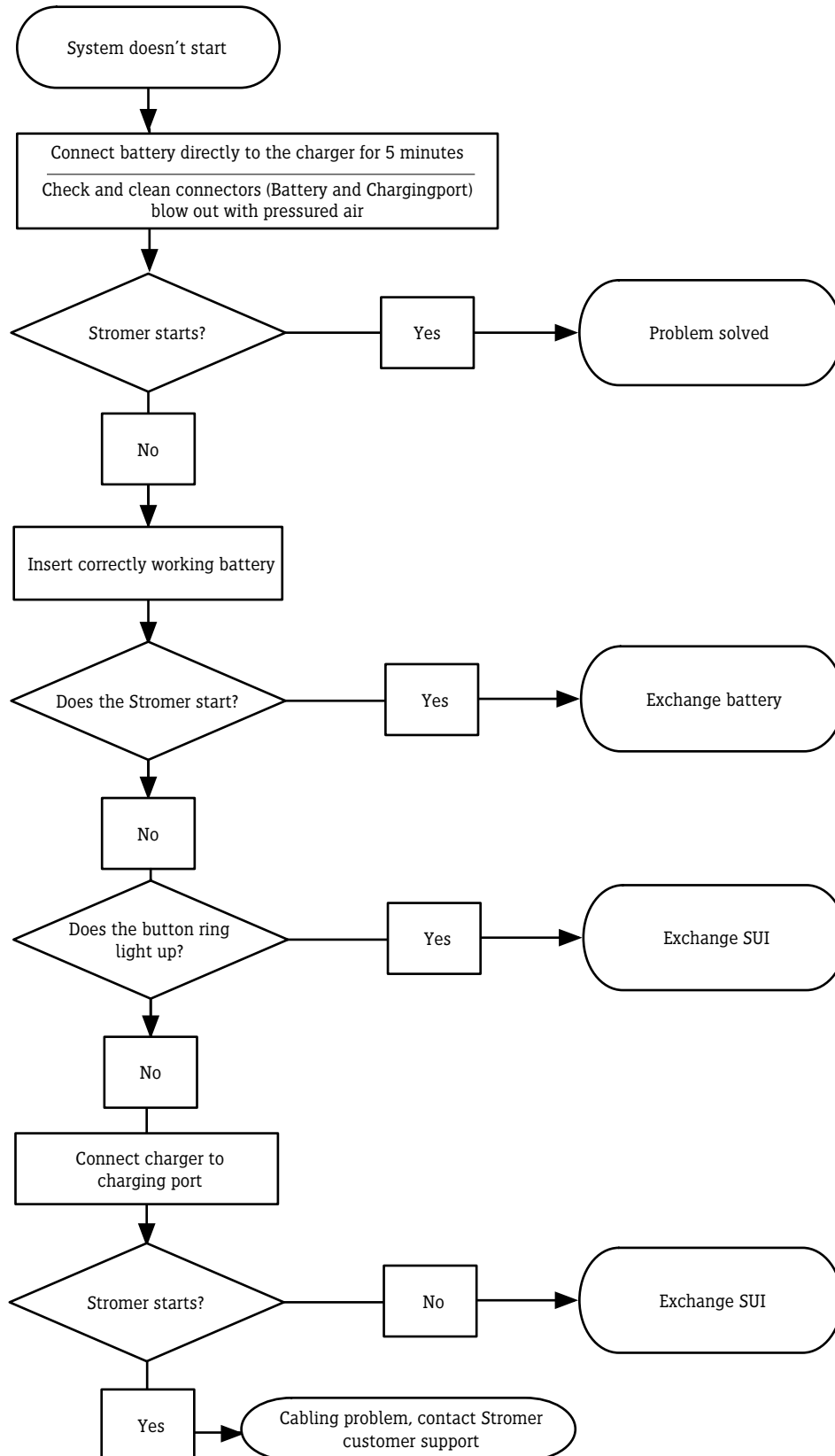

# DIAGNOSIS

## WIRING ST2

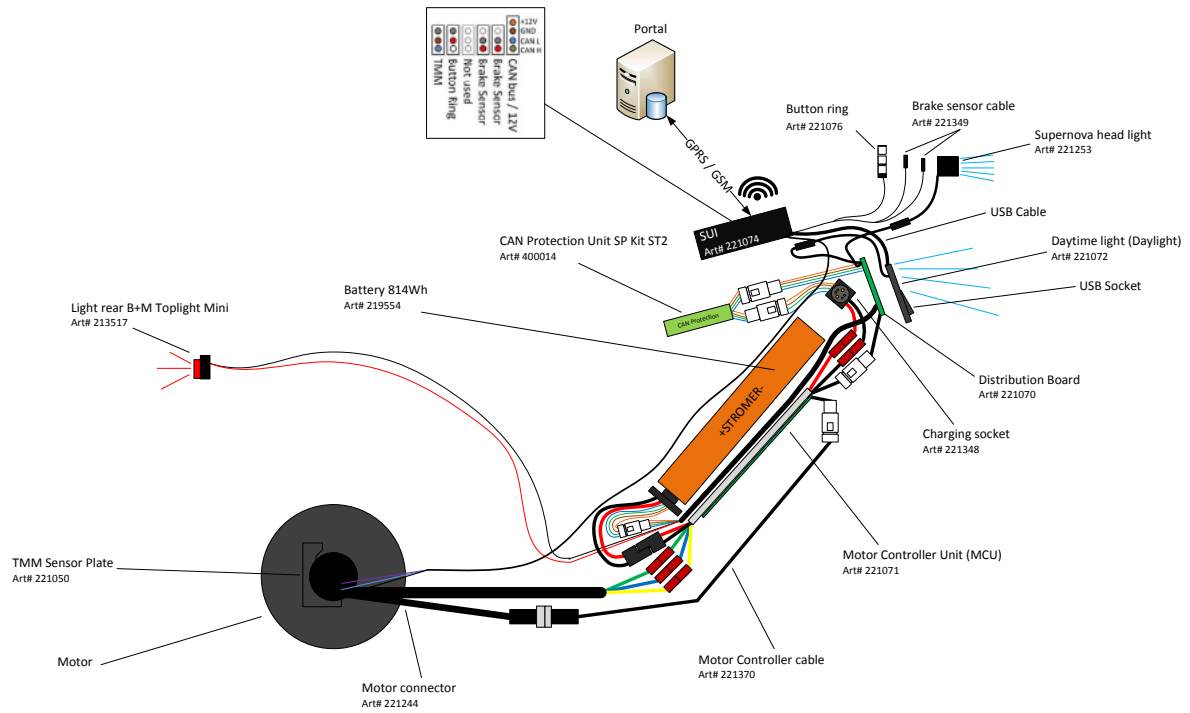

# ST2 WORK INSTRUCTIONS

## CONTROLLER [221071]

### 1 TOOLS

- (1) Hex key, size 2.5
- (2) Hex key, size 3

### 2 INSTRUCTION

#### 2.1 SAFETY



Before any maintenance work, please **remove the battery** from the battery box. Never disconnect or connect a plug while the battery is in the battery box. You thereby avoid the risk of an electric shock and of injury. If the motor is under heavy load for a longer period, e.g. on long ascents, it may over-heat. In order to avoid burns, make sure that you do not touch the engine with your hands, feet or legs.

#### 2.2 DISASSEMBLING

1. Disassemble the axle nut cover [221345]
  - a. Remove the two screws with hex key (1)



2. Disassembly the heatsink cover [221246]
  - a. Remove the six screws with hex key (2)

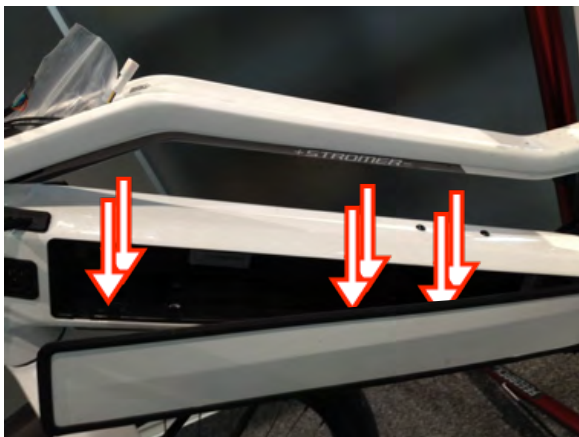

3. Pull the cables out of the hole and disconnect the connector to the wicket [221238] (2 pin) and the 3 phase cables from motor connector [221244]

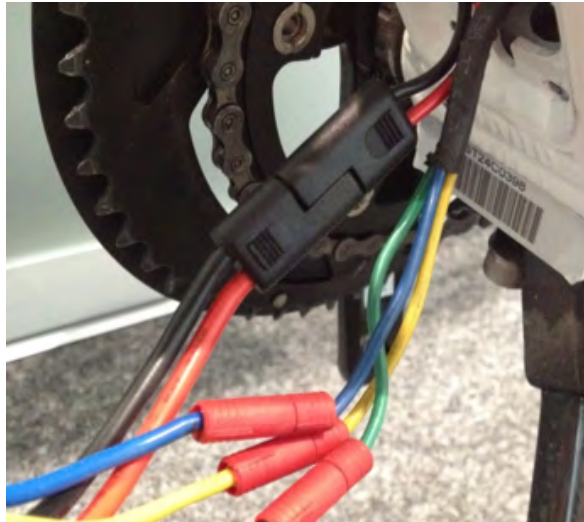

4. Disconnect the cables to distribution board [221070] (8 pin), motor controller cable [221370] (8 pin) and two cables to charging socket [221348]

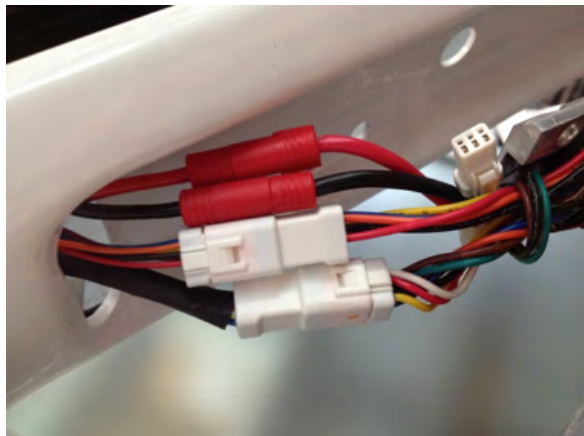

#### 2.3 ASSEMBLING

1. Assemble the controller in the reverse order of disassembly
2. Run the system integrated test (SIT)
3. Send VIN (vehicle identification number) and controller serial number to Customer Service

# ST2 WORK INSTRUCTIONS

## ST2 INTERFACE [221074]

### 1 TOOLS

- (1) SUI nut tool ST2, 221078
- (2) Phillips screwdriver (PH), size 0

### 2 INSTRUCTION

#### 2.1 SAFETY



Before any maintenance work, please remove the battery from the battery box. Never disconnect or connect a plug while the battery is in the battery box. You thereby avoid the risk of an electric shock and of injury. If the motor is under heavy load for a longer period, e.g. on long ascents, it may overheat. In order to avoid burns, make sure that you do not touch the engine with your hands, feet or legs.

#### 2.2 DISASSEMBLY

1. Remove the power button with the SUI nut tool (1)
2. Remove the interface

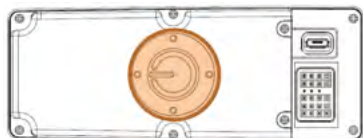

- a. Push upwards with the backside of a screwdriver

3. Remove the Interface cover



- a. Remove 4 screws with screwdriver (2)
4. Detach the connectors

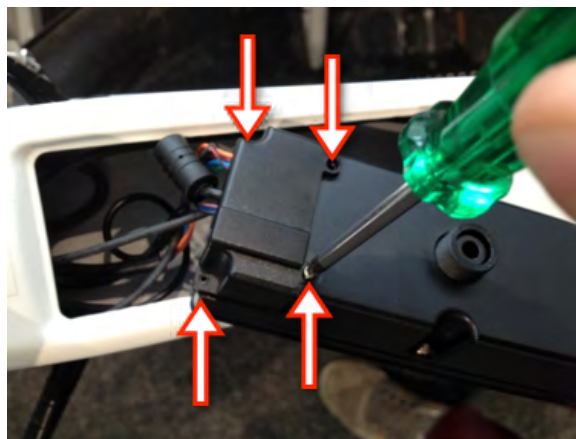

#### 2.3 REASSEMBLY

1. Plug in the connectors on the SUI

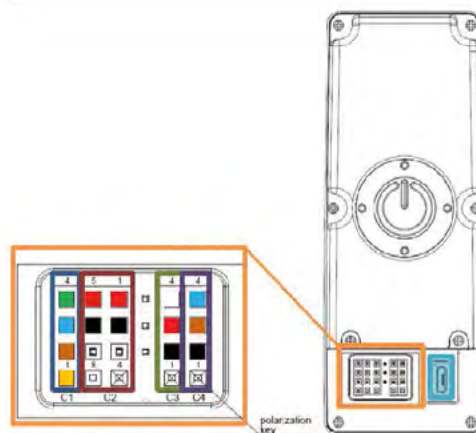

- a. C1: Distribution board [221070]
- b. C2: Brake sensor cable [221349]
- c. C3: Button ring [221076]
- d. C4: TMM sensor [221050]
- e. USB Daylight [221072]

2. Assemble the interface in the reverse order of disassembly
3. Run the system integrated test (SIT)
4. Send VIN (vehicle identification number) and SUI number to Customer Service

# ST2 WORK INSTRUCTIONS

## BATTERY BOX AND WICKET [221238]

### 1 TOOLS

- (1) Hex key, size 2.5
- (2) Hex key, size 3

### 2 INSTRUCTION

#### 2.1 SAFETY



Before any maintenance work, please **remove the battery** from the battery box. Never disconnect or connect a plug while the battery is in the battery box.

You thereby avoid the risk of an electric shock and of injury. If the motor is under heavy load for a longer period, e.g. on long ascents, it may overheat. In order to avoid burns, make sure that you do not touch the engine with your hands, feet or legs.

#### 2.2 DISASSEMBLY

1. Disassemble the axle nut cover [221345]
  - a. Remove the two screws with hex key (1)

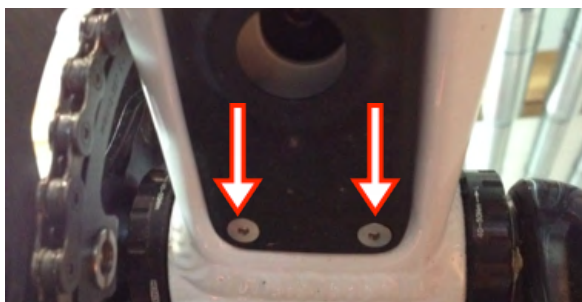

2. Disassemble the heatsink cover [221246]
  - a. Remove the six screws with hex key (2)

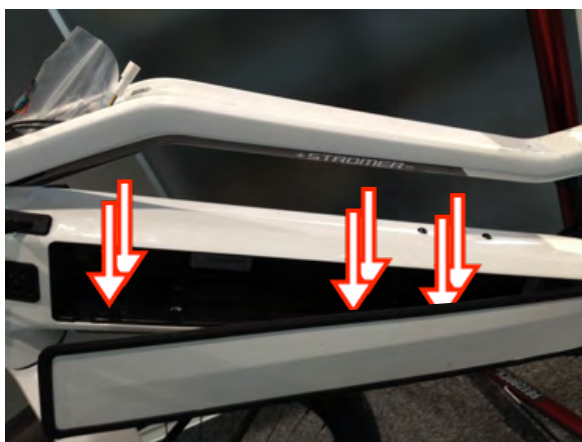

3. Remove the six screws from battery box with hex key (2)



4. Pull the box outside from the top



# ST2 WORK INSTRUCTIONS

## BATTERY BOX AND WICKET [221238]

5. Disconnect the two connectors
  - a. Power to controller [221071] (2 pins)
  - b. Communication to distribution board [221070] (4 pins)
3. Assemble the battery box in the reverse order of dis-assembly
4. Run the system integrated test (SIT)

### 2.3 REASSEMBLY

1. Pay attention to the cables behind the battery box
  - a. The cables must be in the correct position inside the frame

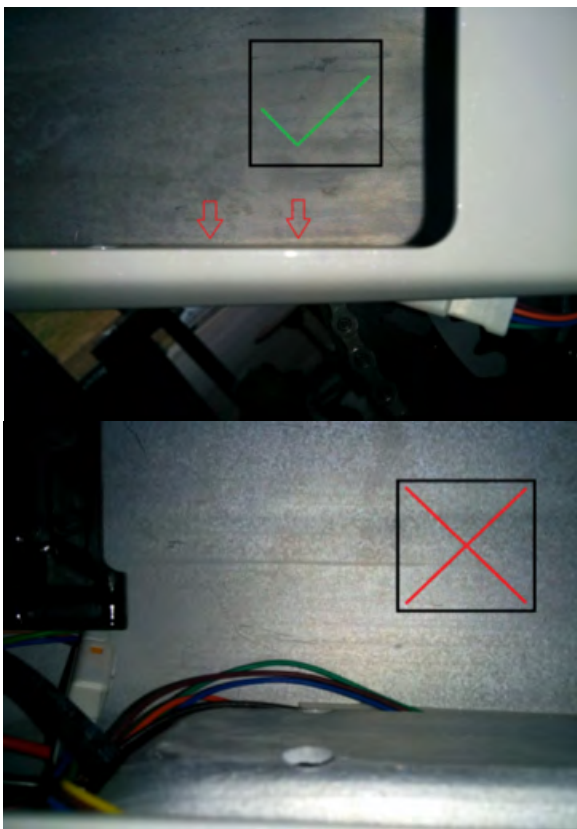

- b. Should the cables stick out from the frame, the battery box cannot be correctly assembled. So the locking mechanism's function will be impaired
2. Remove the Anti tampering sticker (a) and manufacturer's data plate (b) from the old battery box and put it on the same position in the new battery box

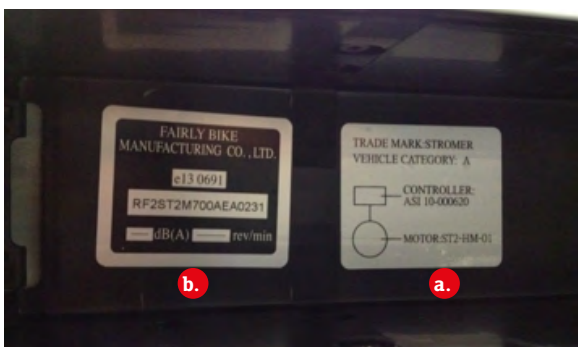

# ST2 WORK INSTRUCTIONS

## MOTOR CONNECTOR [221244]

### 1 TOOLS

- (1) Hex key, size 2.5
- (2) Hex key, size 3
- (3) Hex key, size 5

### 2 INSTRUCTION

#### 2.1 SAFETY



Before any maintenance work, please **remove the battery** from the battery box. Never disconnect or connect a plug while the battery is in the battery box. You thereby avoid the risk of an electric shock and of injury. If the motor is under heavy load for a longer period, e.g. on long ascents, it may overheat. In order to avoid burns, make sure that you do not touch the engine with your hands, feet or legs.

#### 2.2 DISASSEMBLY

1. Disassemble the axle nut cover [221345]
  - a. Remove the two screws with hex key (1)



2. Disassembly the heatsink cover [221246]
  - a. Remove the six screws with hex key (2)

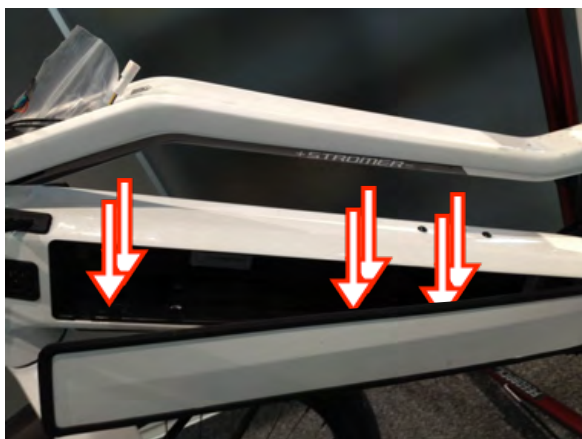

3. Remove the six screws from battery box with hex key (2)



4. Pull the box outside from the top



5. Disconnect the two connectors
  - a. Power to controller [221071] (2 pins)
  - b. Communication to distribution board [221070] (4 pins)



# ST2 WORK INSTRUCTIONS

## MOTOR CONNECTOR [221244]

6. Remove the motor
  - a. Shift to the smallest rear sprocket (the highest gear)
  - b. Loosen the rear axle [221245] with a hex key (3) and pull out the rear axle
  - c. Pull the rear derailleur back slightly
  - d. Lift the ST2. With a light knock on the wheel with your palm from above, it should detach from the frame
  - e. Pull on the small silver tab to disconnect the plug to the motor
7. Disconnect the motor controller cable [221370] (5 pin)

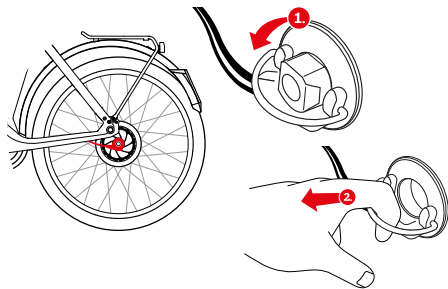

8. Disconnect the 3 phase cables from motor controller



[221071]

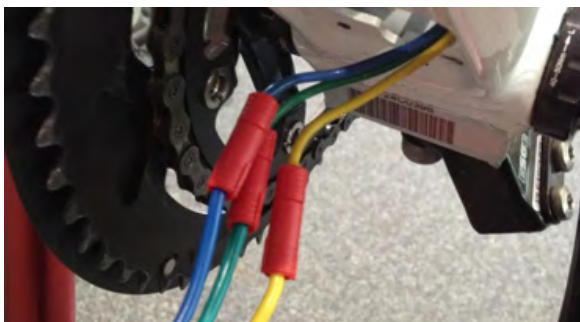

9. Remove the brake calliper
10. Pull the cables out of the chain stay to the rear
  - a. First, the 3 phase cables to the controller [221071]
  - b. Second, the motor controller cable [221370]

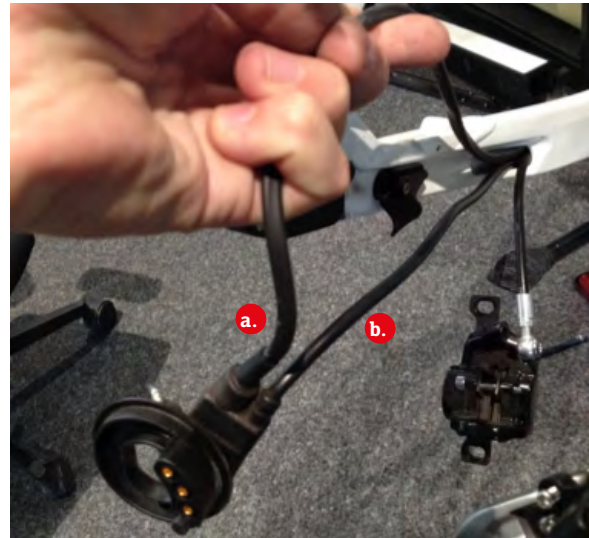

### 2.3 REASSEMBLY

1. Pay attention to the cables behind the battery box
  - a. The cables must be in the correct position inside the frame
  - b. Should the cables stick out from the frame, the battery box cannot be correctly assembled. So the locking mechanism's function will be impaired

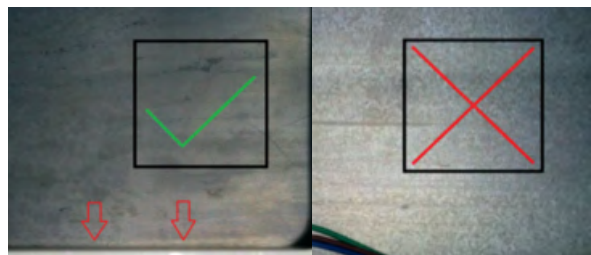

- c. The position of the motor controller cable [221370] connector

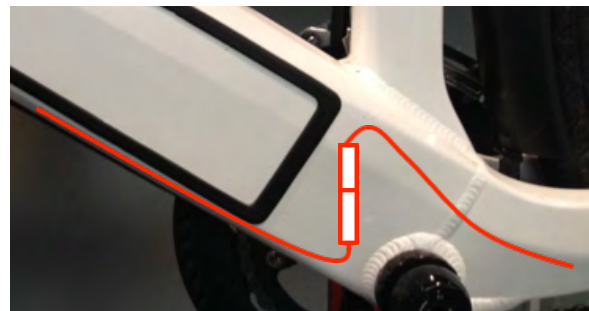

2. Assemble the motor connector in the reverse order of disassembly
3. Run the system integrated test (SIT)

# ST2 WORK INSTRUCTIONS

## ST2 SERVICE MENU

Settings and functions that are not required in normal operation are hidden in a Service menu.

### 1 CALLING UP THE SERVICE MENU

1. Press the power button to access the shortcut screen.

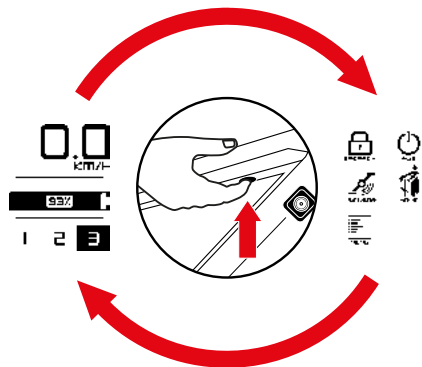

5. The Service menu can be found under the **SERVICE** heading.

2. Apply the right-hand brake and hold it applied.



3. Select **MENU** and hold it pressed.
4. Release the right-hand brake

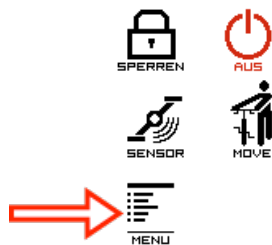

Keep **MENU** pressed until the menu opens



# ST2 WORK INSTRUCTIONS

## ST2 SERVICE MENU

### 1.1 SERVICE SETTINGS

#### 6. **SIT ENABLE**

See: ST2 - Work Instruction - System Integration Test

#### **DAYLIGHT**

See: ST2 - Work Instruction - Daytime running lights settings



### 1.2 ERROR LIST

#### 7. **Error list**

If the last error messages have not yet been sent to the Stromer Portal, they are displayed in the error list.

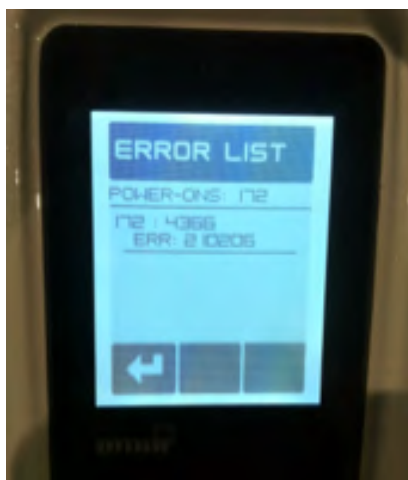

### 1.3 SENSOR

#### 8. **TORQ.SENS.**

The TMM sensor is reset at the black button: TMM RESET

See: ST2 Diagnosis Flow Chart - ST2 not assisting



#### **BRAKEMODE**

Test whether the brake sensors are recognized and are functioning correctly.

REL = brake is released

PUL! = brake is applied

# ST2 WORK INSTRUCTIONS

## DAYTIME RUNNING LIGHTS SETTINGS

The daytime running light on all ST2 bikes is set to the European standard at the time of delivery. These settings can be adjusted in the Service menu as required.

### 1 LEGAL

The following rules apply in Switzerland and in much of the EU. However, you should always familiarize yourself with the local laws before changing any settings.

#### 1.1 EU

The daytime running light integrated into the ST2 head tube is regarded legally as a position lamp in the European Vehicle Type Approval and must therefore always be operated in conjunction with the rear light in the EU.

Since 1, 2016, on all new vehicles being brought into circulation the light must come on automatically as soon as the motor is ready for travel. The rider can switch the low-beam headlight off manually at the light switch. However we recommend leaving the low-beam headlight switched on and only switching it off to comply with local road traffic regulations.

#### 1.2 CH

In accordance with Article 179a (2) Provision f of the Ordinance on the Technical Requirements for Road Vehicles as well as Appendix 1 No. 2.1 of the Ordinance on the Type Approval of Vehicles, since Yesnuary 1, 2014 a daytime running light has been permitted on motor-assisted bicycles in addition to the specified lighting equipment. It does not need to comply with any particular standard. In Switzerland, the daytime running light integrated into the ST2 head tubemay therefore be activated independently of the rear light.

### 2 SETTINGS

From SUI FW 2.0.0, the following settings are available in the Service menu. The response of the settings differs from SUI FW version 1.x.x in order to comply with the new statutory requirements in the EU.

The following settings are available in the Service menu:

DL Autonom: determines whether the Stromer daytime running light is on when the low-beam headlight is switched off. Daylight: determines whether the Stromer daytime running light is on when the low-beam headlight is switched on.

The permitted and recommended setting depends on the country and the vehicle specification:

RECOMMENDED DAYTIME RUNNING LIGHT SETTING	EU	CH / USA
<b>ST2 WITH DISTRIBUTION BOARD (REV. A)</b> (Rear light NOT lit when daytime running light switched on and low-beam headlight switched off)	DL Autonom = OFF Daylight = ON (OFF)	DL Autonom = ON (OFF) Daylight = ON (OFF)
<b>ST2 WITH DISTRIBUTION BOARD (REV. B)</b> (Rear light lit when daytime running light switched on and low-beam headlight switched off)	DL Autonom = OFF	DL Autonom = ON (OFF) Daylight = ON (OFF)
<b>ST2 S</b> (equipped with M99-Pro for high beam)	DL Autonom = N/A Daylight = ON (OFF)	DL Autonom = N/A Daylight = ON (OFF)



# ST2 REGULATIONS

The regulations and requirements for e-bikes are continuously being revised and may change at any time. Obtain information regarding the valid legal requirements so that you are always up to date.

For S-pedelects, special provisions apply for their limit of use. This means that e-bikes are sometimes operated like a bicycle and at other times not.

Before riding on public roads with your Stromer, inform yourself about the current legal requirements enforced in your country. This information can be found at the respective national bike or e-bike associations and online.

There you can obtain information on how your Stromer must be equipped in order to drive in traffic on public roads. These sources describe, for example, which lighting systems have to be installed and which brakes the S-pedelect must have.

The currently valid, national regulations also deal with age restrictions and specify from which age people are allowed to drive on which part of the road and whether certain driving permits are required.

The regulations for children riding on public roads are also found here. It will be made clear if a helmet is required to be worn by law.

## REPLACING PARTS

Specific components are defined in the approvals process which are allowed to be used on this vehicle.

Use original parts or replacement parts for which an expert opinion regarding the approval for your S-pedelect exists, or obtain an individual permit from the relevant licensing authority.

Parts which must only be replaced like-for-like or with approved parts are as follows:

1. Frame
2. Fork
3. Motor unit
4. Battery
5. Tires
6. Rims
7. Brake system
8. Front light
9. Rear light
10. Number plate holder
11. Side stand
12. Handlebars
13. Stem

## DEAR CUSTOMER,

We would like to start by congratulating you on your new Stromer and provide you with some important information regarding your new premium vehicle.

It will help you use this technology more effectively and prevent risks. Please carefully read these operating instructions and keep them in a safe place.

The Stromer you have received has been assembled and adjusted according to your body type. If this isn't the case, please contact a Stromer shop to have this necessary work performed on your bike.

It is assumed that the bike's user has acquired the basic and needed knowledge to operate this pedelec. All persons involved in

- using,
- repairing or maintaining,
- cleaning
- or disposing of

this pedelec must have fully read and understood the content and meaning of these operating instructions. Make sure to ask a Stromer dealer if

All information in these operating instructions relate to structure, technology, care and maintenance. Please adhere to this information, as it is often safety-related and disregard it may lead to severe accidents and economic damage.

We have only described the most important issues, as modern S-pedelects have very powerful technology.

The instructions of the respective manufacturers of the components used must be consulted for special, technical details. They can be found on the Internet at [www.stromerbike.com/support](http://www.stromerbike.com/support)



QR Code for Stromer support



Check which driving license you need to ride

# MODEL YEAR 16

## QUESTIONS AND ANSWERS

- Suspension forks for the ST2 S model
- Suspension forks for the ST1 Limited Edition, ST1 S and ST1 T
- Differences in size between the 22 Sport and 20 Sport versions of the ST2 S and ST2 models
- Additional spare brake parts for the ST1
- Aftermarket tires: legal requirements and availability
- Schlumpf drive: technical differences between the ST1 S and the ST1 T
- Schlumpf drive spare parts: available to buy via Stromer
- Lighting system: upgrades for the ST2

### WILL THE ST2 S BE AVAILABLE WITH SUSPENSION FORK IN FUTURE?

- Available suspension fork spare part kits for the ST2 can also be used for the ST2 S
  - Gloss Black = 400031
  - Matte Black = 400032
  - This spare parts kit contains all the small parts which are needed for installation
    - Magura disk brake adapter, conical washer and insert
    - FSA crown race, top cap set & spacer
    - Busch & Müller reflectors
    - Stromer fender kit for suspension forks
- There are no plans to produce an additional kit to match the gray version of the ST2 S
  - The demand would be too low to reach the minimum order quantities
  - It would be very complex and expensive to match the color

### WILL THERE BE SUSPENSION FORK SPARE PARTS KITS FOR THE ST1 LE, ST1 S AND ST1 T MODELS?

- The existing ST1 suspension forks can also be used for the ST1 S and ST1 T models
  - Gloss Red = 400241
  - Gloss White = 400242
  - Matte Black = 400244
- There are no plans to make suspension forks matching the colors of the new ST1
  - ST1 Limited Edition, Matte Blue
  - ST1 S, Gloss Green
  - ST1 T, Matte Brown

### IN WHAT RESPECTS DO THE 20 SPORT AND THE 22 SPORT DIFFER IN SIZE?

- The seat tube on the 22 Sport is 51 mm longer
- The top tube on the 22 Sport is 23 mm longer (both horizontal and reach)
- There is no change to the steering tube length and stack on the 22 Sport

### WHAT WILL THE STANDARD STEM LENGTH BE ON THE ST2 S AND ST2 IN 22 SPORT SIZE?

- The standard stem length on the 22 Sport will be 105 mm
  - That is the same length as the stem on the 20 Sport
- Stems measuring 120 mm in length will be available for customers who would like a longer reach
  - ST2 = 221256
  - ST2 S = new article number to follow

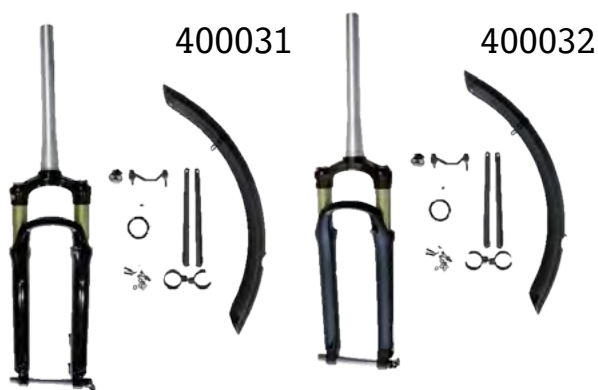

### CAN STROMER MODELS WHICH WERE ORIGINALLY FITTED WITH A MAGURA BRAKE SYSTEM BE UPGRADED WITH THE TEKTRO DORADO BRAKE SYSTEM?



## MODEL YEAR 16

### QUESTIONS AND ANSWERS

ST1: Yes

- The Tektro brake system has the L1e type approval for all ST1 models
- The plug for the sensor on the rear wheel brake is identical

ST2: No

- The Tektro brake system does not have L1e type approval for the ST2

#### WHICH COMPONENTS OF THE TEKTRORADO WILL STROMER STOCK IN SPARE PARTS KITS FOR THE ST1?

- Front wheel brake unit = 400263
- Rear wheel brake unit = 400264
- Spare brake parts kit = 400267
  - A kit will be supplied with each ST1, ST1 S and ST1 T in model year 2016
- Brake pads E10.11 (standard, low-noise) = 400265
- Brake pads P20.11 (optional, high-performance) = 400266
- Brake disk TR180-1 = 400268
- 



#### CAN THE CONTINENTAL TOP CONTACT II TIRES WHICH ARE FITTED AS STANDARD ON THE ST2 S AND ST1 S MODELS ALSO BE USED FOR OTHER MODELS?

- Yes, on all Stromer models with valid L1e type approval certificates
  - These tires are marked with an E attesting to their ECE R75 conformity
  - 50-559 is one of several tire sizes which are approved according to L1e certificates

#### IS STROMER INTENDING TO KEEP A STOCK OF THE CONTINENTAL TOP CONTACT II TIRES AS SPARE PARTS?

- No, it is exactly the same design as the one kept in stock in the after-sales section
  - Continental # 0100442

#### SO WHY DOES STROMER STOCK THE SCHWALBE BIG BEN TIRES AS SPARE PART 213619?

- Because these are made specially for Stromer
- The GreenGuard layer improves puncture protection
- They bear the Stromer logo so that they can be clearly distinguished from the standard tires



#### WHAT DIFFERENCES ARE THERE BETWEEN THE SCHLUMPF SPEED DRIVE GEARS ON THE ST1 S AND ST1 T?

- Chain rings (Fig. 27)
  - ST1 S: A chain ring with 32 actual teeth equates to a virtual chain ring with 53 teeth when shifting up
    - A large chain ring as on the ST1 Elite, together with a second set of smaller chain rings
  - ST1 T: A chain ring with 30 actual teeth equates to a virtual chain ring with 50 teeth when shifting up
    - Same as on the ST1 Platinum with just two chain rings and less overlap
- Clothing guard disks (Fig. 29)
  - ST1 S: Designed to fit the larger 32-tooth chain ring
  - ST1 T: Designed to fit the smaller 30-tooth chain ring
- Pressure plates (Fig. 30)
  - ST1 S: silver
  - ST1 T: black



# MODEL YEAR 16

## QUESTIONS AND ANSWERS

### WHICH SPARE PARTS DOES STROMER INTEND TO SUPPLY AS BACKUP FOR THE SCHLUMPF SPEED DRIVE?

- New Stromer article numbers to follow
  - Complete bottom bracket with silver pressure plates
  - Complete bottom bracket with black pressure plates
  - Crank arm, left, 170 mm (Haberstock no. SG-700 011)
  - Crank arm, right, 170 mm (Haberstock no. SG-700 010)
  - Gear shift knobs (pair) (Haberstock no. SG-700 510)
  - 32-tooth chain ring and clothing guard disks (Haberstock nos. SG-602 030 and SG-605 321)
    - These can be used to increase the transmission ratio of the ST1 T
  - 30-tooth chain ring and clothing guard disks (Haberstock nos. SG-602 020 and SG-605 311)
    - These can be used to decrease the transmission ratio of the ST1 S
- Toolset
- Torque wrench
- Ratchet with exchangeable inserts
- Further parts, information and warranty items should be arranged through Haberstock Mobility or the company's local stockists
  - CH & EU: [www.haberstock-mobility.com](http://www.haberstock-mobility.com)
  - US: [www.cyclemonkey.com](http://www.cyclemonkey.com)

- Research
- Development
- Test runs
- Extension of the L1e type approval
- Production
- Dispatch

### EXPLODED VIEW OF A SPEED DRIVE GEAR ASSEMBLY FOR THE ST1 S

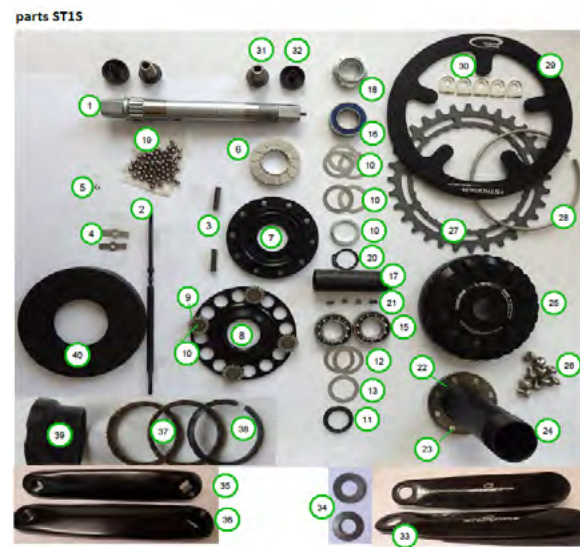

no:	title:	part number:	no:	title:	part number:
1	axle	SG-100 100	21	pressure spring small	SG-400 200
2	shift axle	SG-110 100	22	surround	SG-200 100
3	spring for shift axle	SG-400 100	23	magnets 5mm	SG-401 400
4	clutch plate	SG-350 200	24	housing tube	SG-120 100
5	c - ring d 3	SG-400 000	25	housing	SG-140 200
6	clutch	SG-230 000	26	torx - screw M5	SG-400 500
7	chain disk	SG-220 000	27	chainring 32 teeth	SG-602 030
8	planet carrier	SG-210 100	28	ring spring	SG-402 300
9	planet wheel	SG-240 100	29	trouser guard	SG-605 321
10	planet bolt	SG-240 200	30	pressure plate silver	SG-350 300
11	bearing shell	SG-350 500	31	axle bolt	SG-350 600
12	washer 0,1 mm	SG-400 400	32	gear shift button	SG-350 010
13	washer 0,5 mm	SG-400 500	33	kick plates	SG-700 510
14	washer 2 mm	SG-604 630	34	washer for kick plate	SG-401 500
15	industrial bearing open	SG-403 000	35	crank 170mm right	SG-700 010
16	industrial bearing closed	SG-403 100	36	crank 170mm left	SG-700 011
17	distance tube	SG-351 100	37	spacer 2 mm	SG-606 085
18	safety nut M17	SG-402 500	38	cone ring steel 0.5 mm	SG-606 040
19	balls 4 mm	SG-403 300	39	Nut 6x45°	SG-130 000
20	c - ring d17mm	SG-400 300	40	steel cover inside	SG-310 200

### IS THERE AN UPGRADE KIT IN THE PIPELINE TO FIT THE ST2 WITH THE SUPERNOVA M99 PRO LIGHT SYSTEM, AS INCLUDED IN THE SPECIFICATION FOR THE NEW ST2 S?

Unfortunately not!

- So many components would have to be removed and replaced that it would not be viable due to the disproportionately high cost of labor and parts

### ARE THERE PLANS FOR AN UPGRADE KIT TO FIT THE ST2 WITH A BETTER LIGHT SYSTEM?

- We will continue to test and explore new lighting systems
- There is unlikely to be a new spare parts kit before the fall of 2016



# MODEL YEAR 16

## QUESTIONS AND ANSWERS

### EXPLODED VIEW OF A SPEED DRIVE GEAR ASSEMBLY FOR THE ST1 T

parts ST1T

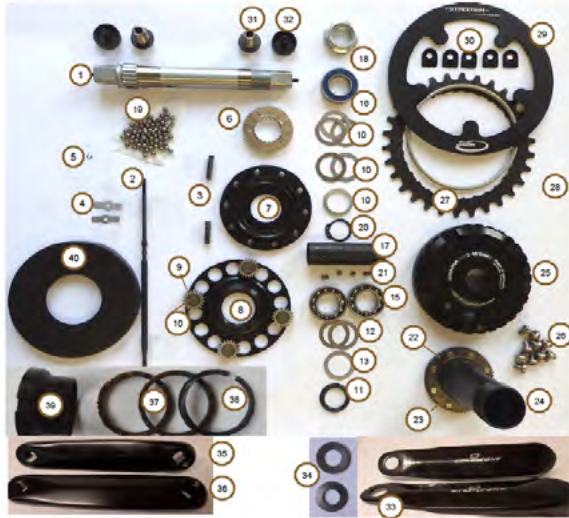

no:	title:	part number:	no:	title:	part number:
1	axle	SG-100 100	21	pressure spring small	SG-400 200
2	shift axle	SG-110 100	22	sunwheel	SG-200 100
3	spring for shift axle	SG-400 100	23	magnets 5mm	SG-401 400
4	clutch plate	SG-350 200	24	housing tube	SG-120 100
5	c - ring d 3	SG-400 000	25	housing	SG-140 200
6	clutch	SG-230 000	26	torx - screw M5	SG-400 500
7	chain disk	SG-220 000	27	churning 30 teeth	SG-602 020
8	planet carrier	SG-210 100	28	ring spring	SG-402 300
9	planet wheel	SG-240 100	29	trouser guard	SG-605 311
10	planet bolt	SG-240 200	30	pressure plate black	SG-350 301
11	bearing shell	SG-350 500	31	axle ball	SG-350 600
12	washer 0,1 mm	SG-400 400	32	gear shift button	SG-350 010
13	washer 0,5 mm	SG-400 500	33	kick plates	SG-700 510
14	washer 2 mm	SG-604 530	34	washer for kick plate	SG-401 500
15	industrial bearing open	SG-403 000	35	crank 170mm right	SG-700 010
16	industrial bearing closed	SG-403 100	36	crank 170mm left	SG-700 011
17	distance tube	SG-351 100	37	spacer 2 mm	SG-606 085
18	safety nut M17	SG-402 500	38	cone ring steel 0.5 mm	SG-606 040
19	balls 4 mm	SG-403 300	39	nut 6x45°	SG-130 000
20	c - ring d17mm	SG-400 300	40	steel cover inside	SG-310 200

Contact:

**Stromer USA** | 9240 Trade Place Suite 100 | San Diego, CA 92126 | [stromerbike.com](http://stromerbike.com) | [service@stromerbike.com](mailto:service@stromerbike.com)

**Photo credits** | Products: **Andrea Campiche** | Outdoor: **Florian Grill** | **Philipp Ruop**

© **myStromer AG**